



Flipper Pump Mk 4

FRESHWATER

Simple hand operated solution for pumping water in the galley

Features and Benefits

- Manual self priming galley pump
- Ideal for installing between two sinks - swivelling outlet
- Precise flow control
- Easy operation - Light back & forth pump action
- 7 ltrs capacity (1.85 US gals) per minute
- Fine flow control
- Suitable for fresh or saltwater

COMPLETE YOUR SYSTEM

Freshwater system accessories such as water filters, and pipework connections – page 76-77

YOU MAY ALSO LIKE

Whale water filters – page 76
Watermaster Automatic Pressure Pumps – page 54

i Product Information

Model Specifications

Model	Flipper Pump Mk 4
Product Code	GP0418
Hose Connections	Suitable for 13 mm (1/2") Flexible Hose
Weight	0.30 kg (0.71 lbs)
Materials	Pump Body: Acetal, Nylon, Polystyrene, Polypropylene LM6 Aluminium Alloy, Brass Seals: Neoprene, Nitrile®, ABS Fasteners: Stainless Steel
Service Kit	AK0405 - Service Kit for Flipper Mk3 and Mk4 Models Contains: Diaphragm, Seals, Screws AS0406 - Flipper Overhaul Kit
Maximum Suction Lift	3 m (10 ft)
Maximum Discharge Head	3 m (10 ft)
Maximum Output per Minute	7 ltrs (1.85 US gals)

Note: These specifications are retail items only.
For details of our bulk pack range for boat builders and wholesalers - contact Whale Support.

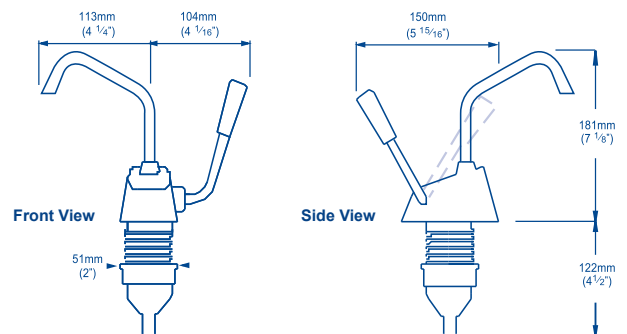

WARNING
Note: Not for use in pressurized systems