

Modèle tout intégré
Il existe d'autres modèles et formes



Sondeur

Pompe de cale manuel

Corne de brume

Feux de navigation

Branchement options schéma général

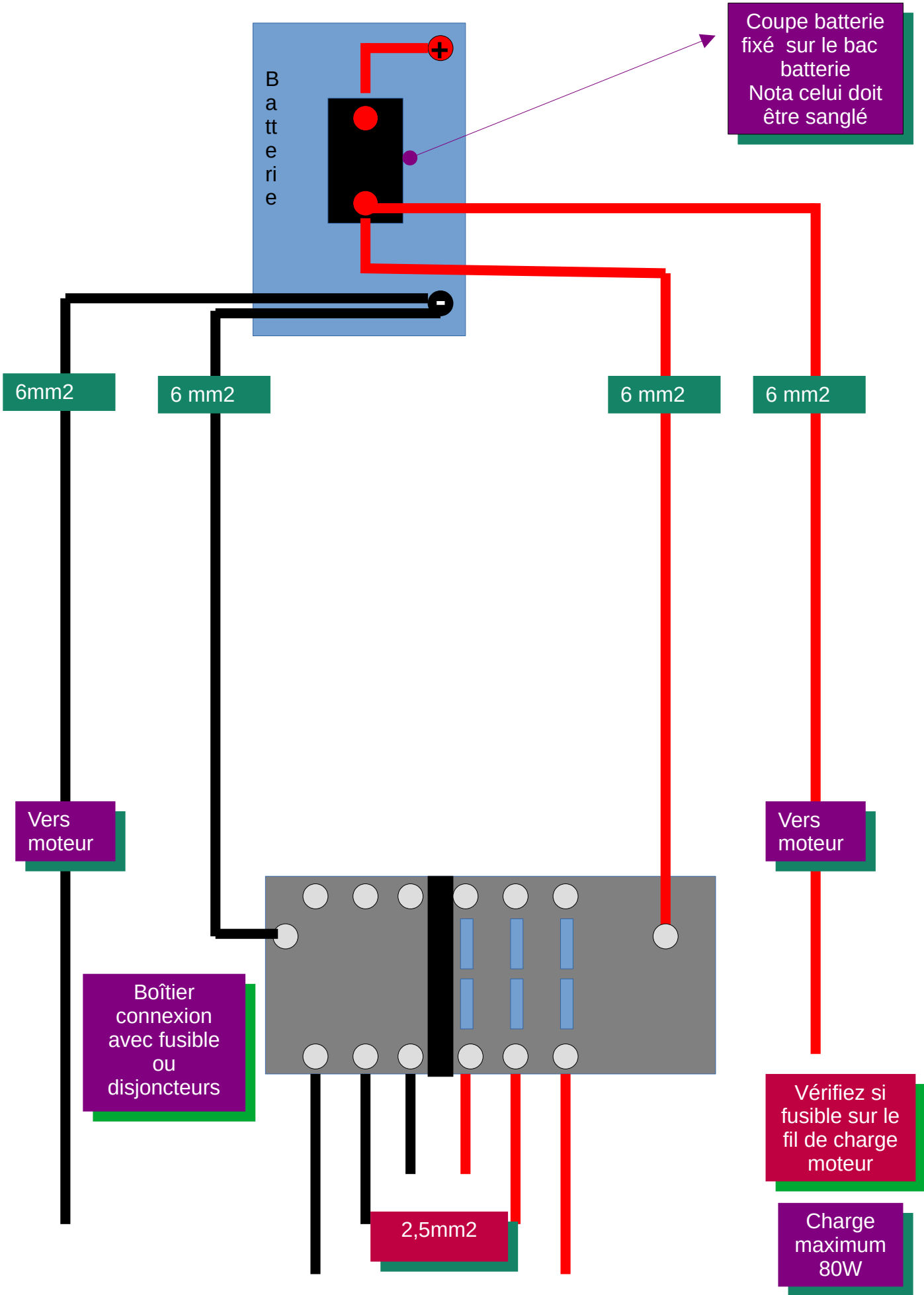

Feux navigations

Nota

Soit 1 feu tout horizon (maxi 8 nœuds)

Ou 1 feu tout horizon + avant vert/rouge

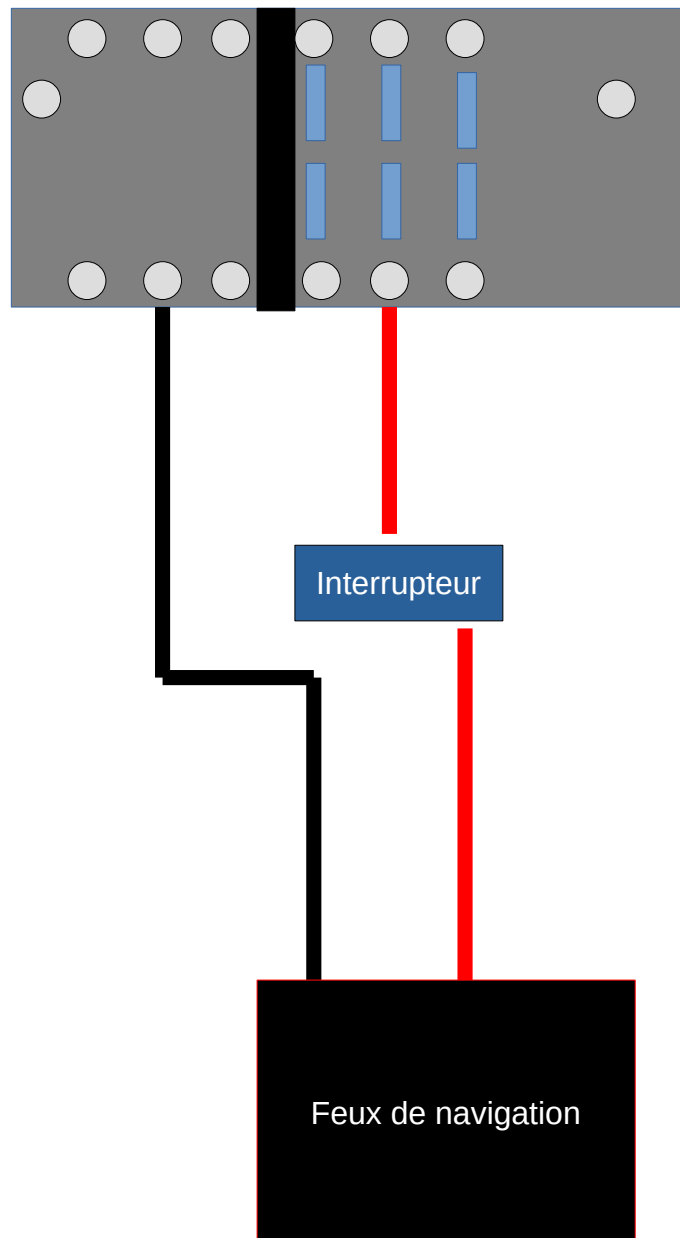

Pompe de cale simple

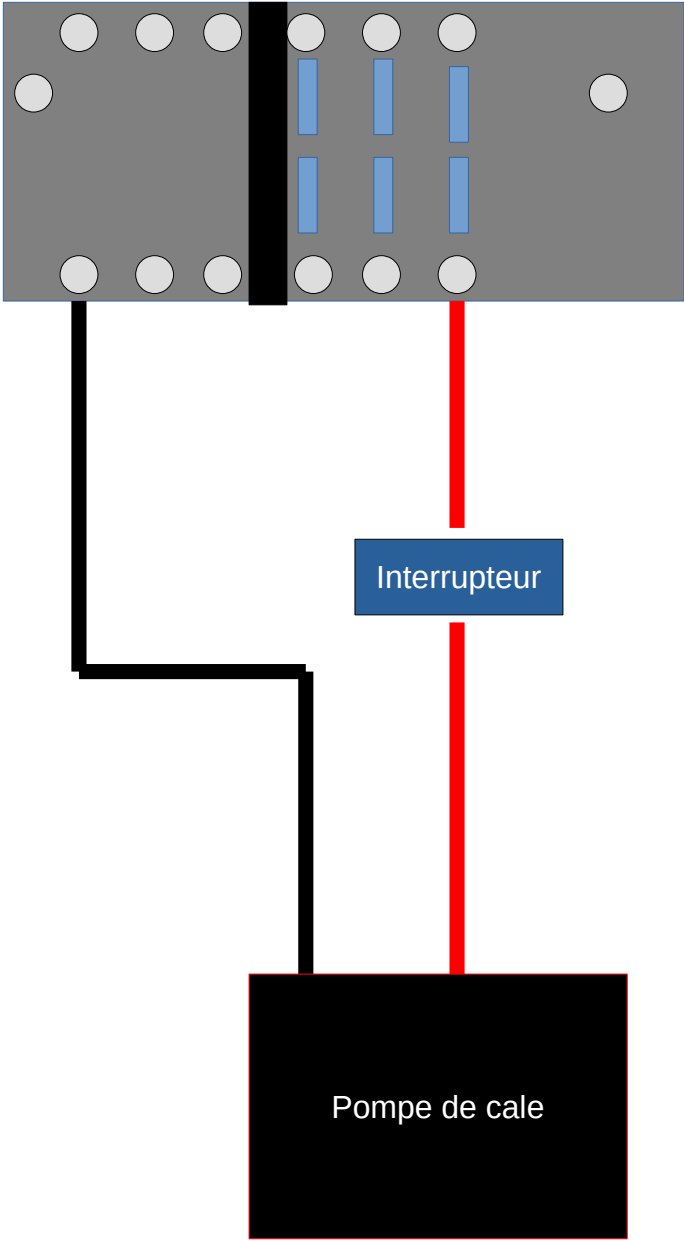

Pompe de cale automatique

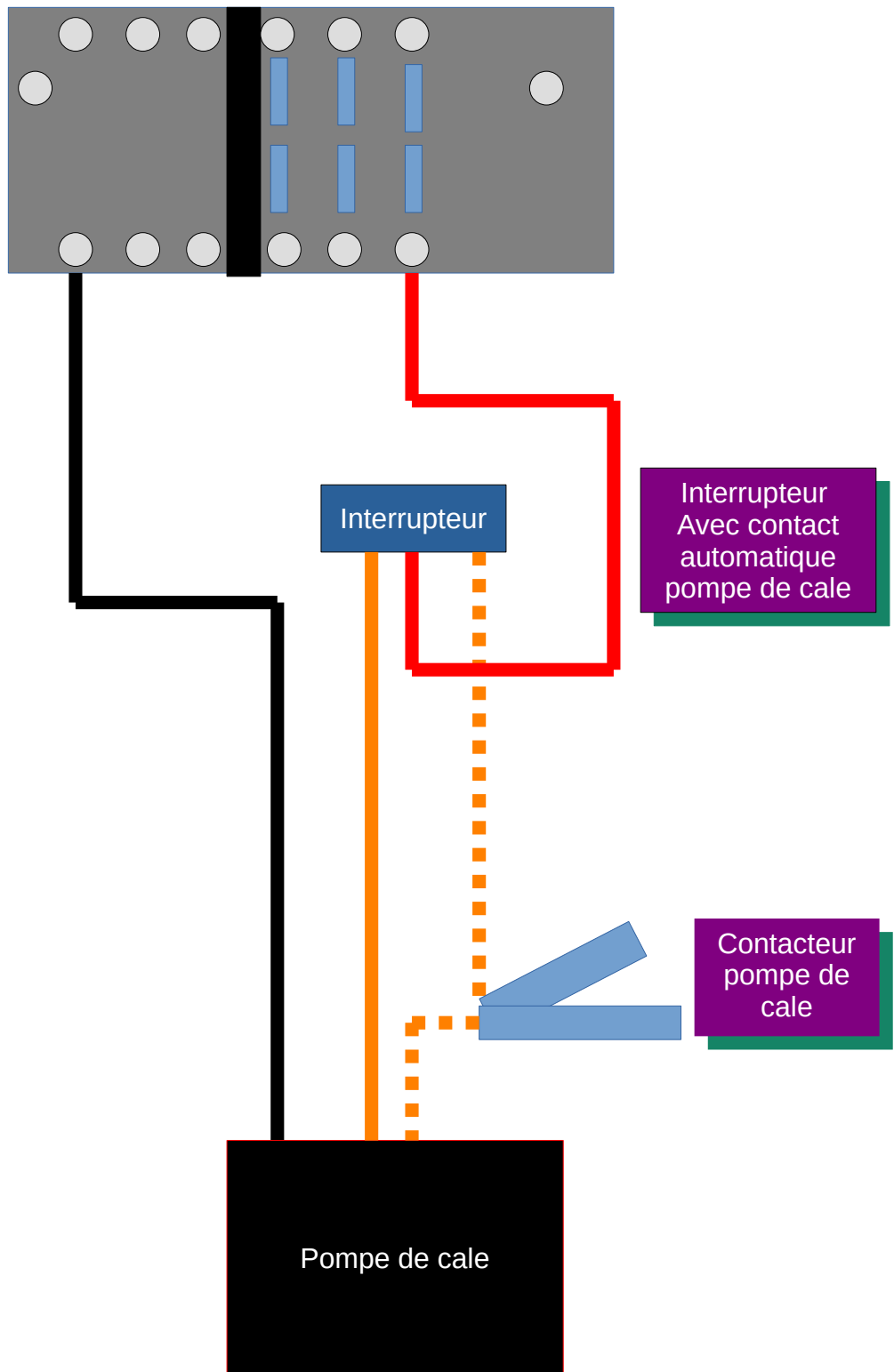

Corne de brume

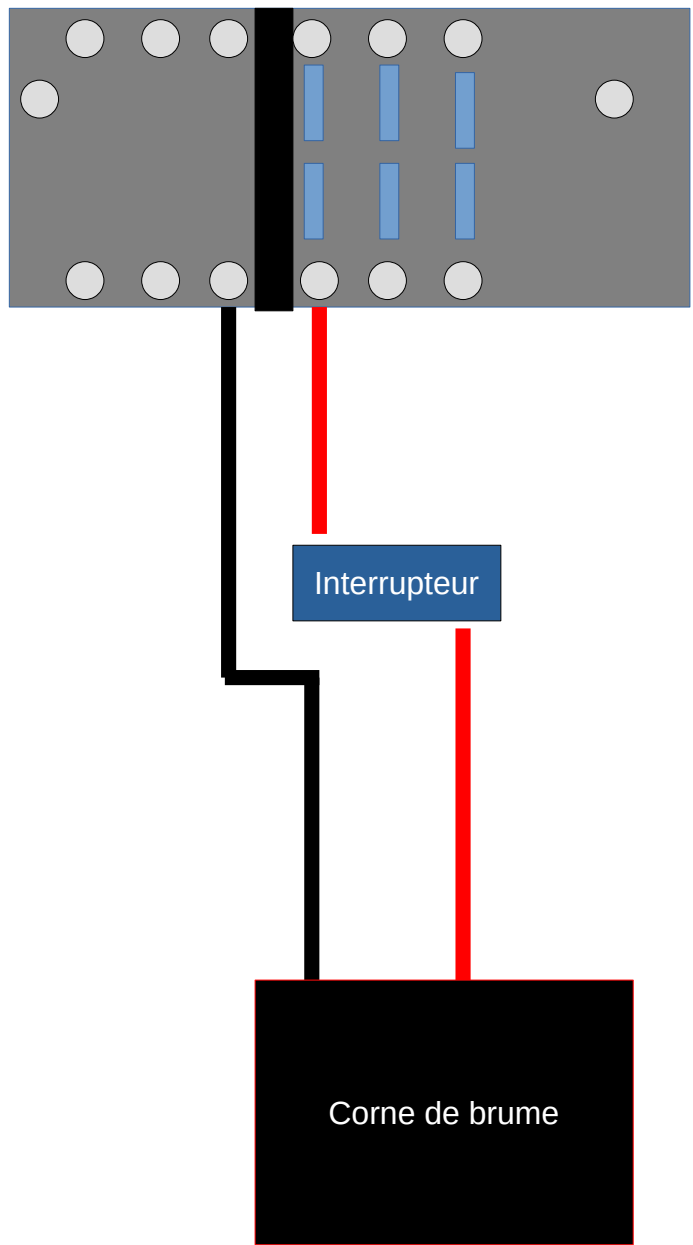

Sondeur

