

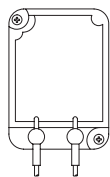

Optional Voltage Regulator Test



1. Check battery voltage at battery with engine running.
2. If battery voltage is above 14.5 volts, replace voltage regulator. Check condition of battery as overcharging may have damaged battery.
3. If battery voltage is below 14.5 volts, charge battery; refer to "Charging a Discharged Battery", preceding. If battery can NOT be satisfactorily charged, replace battery.
4. If battery accepts a satisfactory charge, check battery voltage while cranking engine; refer to "Charging a Discharged Battery", preceding. If cranking voltage is not acceptable, replace battery.
5. If cranking voltage is acceptable, disconnect end of RED wire (located between rectifier (+) terminal and starter solenoid) from rectifier. Secure RED wire (from voltage regulator) to rectifier (+) terminal with hex nut.
6. Connect RED (+) ammeter lead to (+) terminal of rectifier and BLACK (-) ammeter lead to RED wire (disconnected in last step).

IMPORTANT: For accurate test results the voltage at battery with engine running, in next step, must be 13.5 volts or less. It may be necessary to operate electrical accessories to drop voltage to 13.5 volts or less.

7. Run engine at 3000 RPM.
8. Meter should read between 7 - 9 amperes.
9. If meter reads 7 - 9 amperes, this indicates the charging system is functioning properly and the battery is being discharged because the amperage draw on the system is greater than the amperage output of the system.

NOTE: With engine running at the following RPM'S, the ammeter should indicate the following approximate amperes:

RPM	AMPERES
IDLE	1
1000	4
2000	8
3000	9

10. If the meter reads less than 7 amperes, test the stator; refer to "Standard Stator (Alternator Coils) Amperes Output", following. If stator tests OK, replace voltage regulator.

Battery Charging System (9 Ampere Alternator)

Description

The battery charging system components are the stator, rectifier, and battery. Alternating current (generated in stator alternator coils) flows to the rectifier, which changes the alternating current to direct current for charging the battery.

MODELS EQUIPPED WITH RECTIFIER

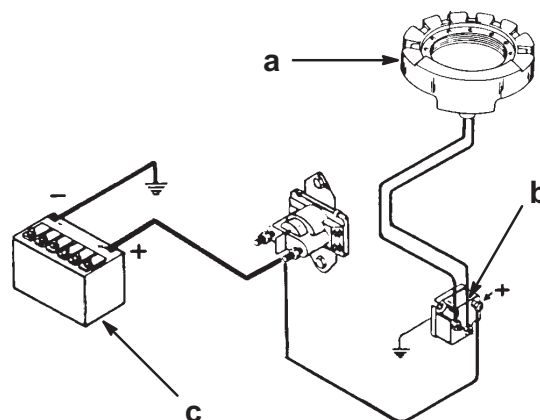

- a - Stator
- b - Rectifier
- c - Battery

MODELS EQUIPPED WITH REGULATOR

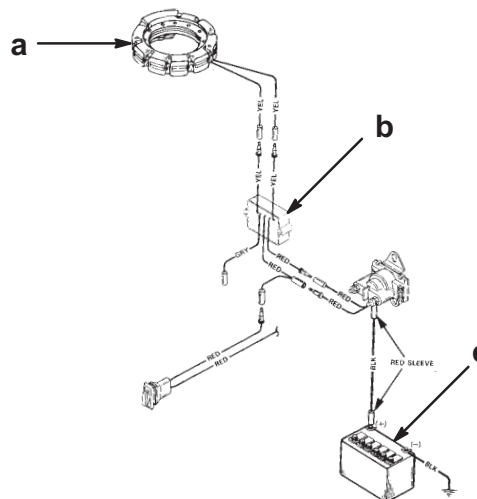

- a - Stator
- b - Regulator
- c - Battery

The charging system may be damaged by: 1) reversed battery cables, 2) running the engine with battery cables disconnected and stator leads connected to rectifier, and 3) an open circuit, such as a broken wire or loose connection.



Battery Charging System Troubleshooting

A fault in the battery charging system usually will cause the battery to become undercharged. Check battery electrolyte level, and charge battery. See “Electrolyte Level”, and “Charging a Discharged Battery”.

If battery will NOT accept a satisfactory charge, replace battery.

If battery accepts a satisfactory charge, determine the cause of the charging system problem as follows.

1. Check for correct battery polarity [RED cable to positive (+) battery terminal]. If polarity was incorrect, check for damaged rectifier. See “Rectifier Test”, following.
2. Check for loose or corroded battery connections.
3. Visually inspect wiring between stator and battery for cuts, chafing; and disconnected, loose or corroded connection.
4. Excessive electrical load (from too many accessories) will cause battery to run down.

If visual inspection determines that battery connections and wiring are OK, perform the following stator and rectifier tests.

Stator Ohms Test (Alternator Coils Only)

NOTE: Stator can be tested without removing from engine.

1. Disconnect both YELLOW (stator leads) from terminals on rectifier (or terminal block).

2. Use an ohmmeter and perform the following test.

IMPORTANT: If stator is mounted on engine, black stator lead (if provided) must be grounded to powerhead when testing.

3. Replace stator if readings are outside ranges shown.

Test Leads	Resistance (Ohms)	Scale Reading (x _____)
9 AMPERE STATOR		
Between YELLOW stator leads	.6 – 1.1*	.6 – 1.1* (R x 1)
Between either YELLOW stator lead and engine ground**	No Continuity	No Continuity (R x 1000)
16 AMPERE STATOR		
Between YELLOW stator leads	.17 – .19	.17 – .19 (R x 1)
Between either YELLOW stator lead and engine ground**	No Continuity	No Continuity (R x 1000)
24 AMPERE STATOR		
Between YELLOW stator leads	.05 – .15	.05 – .15 (R x 1)
Between either YELLOW stator lead and engine ground**	No Continuity	No Continuity (R x 1000)

* DC resistance of these windings generally is less than 1.5 ohms. If a reading (resembling a short) is obtained, this would be acceptable.

** If stator is removed from engine, connect test lead to black stator lead, if provided.

4. If meter readings are other than specified, replace stator.



Standard Stator (Alternator Coils)

9 Amperes Output

IMPORTANT: Rectifier must be functioning properly for accurate test results to be obtained.

1. If engine is equipped with a voltage regulator, disconnect voltage regulator leads at rectifier; reinstall hex nut on rectifier terminal that has yellow stator lead.
2. Remove red wire from (+) terminal of rectifier.
3. Connect RED (+) ammeter lead to rectifier (+) terminal and BLACK (-) ammeter lead to red rectifier wire.
4. Run engine at 3000 RPM.
5. Meter should read 7 - 9 amperes; if not, replace stator.

16 Amp Alternator System Test

(LARGE FINNED VOLTAGE REGULATOR/RECTIFIER)

1. Check battery voltage at battery with engine running.
2. If battery voltage is above 14.5 volts, replace voltage regulator/rectifier. Check condition of battery as overcharging may have damaged battery.
3. If battery voltage is below 14.5 volts, charge battery; refer to "Charging a Discharged Battery", preceding. If battery can NOT be satisfactorily charged, replace battery.
4. If battery accepts a satisfactory charge, check battery voltage while cranking engine; refer to "Charging a Discharged Battery", preceding. If cranking voltage is not acceptable, replace battery.
5. If cranking voltage is acceptable, disconnect RED harness wire from center terminal.
6. Secure RED wire (d) on terminal (c) using hex nut.
7. Connect RED (+) ammeter lead to terminal (c) and BLACK (-) ammeter lead to RED harness wire (b).
8. Secure wires away from flywheel.

IMPORTANT: For accurate test results the voltage at battery with engine running, in next step, must be 13.5 volts or less. It may be necessary to operate electrical accessories to drop voltage to 13.5 volts or less.

9. With engine running at the indicated RPM's, the ammeter should indicate the following approximate amperes:

<u>RPM</u>	<u>AMPERES</u>
IDLE	2
1000	10
2000	17
3000	18

10. If ammeter indicates approximately 18 amperes at 3000 RPM, this indicates the charging system is functioning properly and the battery is being discharged because the amperage draw on the system is greater than the amperage output of the system.
11. If ammeter reads less than 18 amperes, test the stator; refer to "Stator Ohms Test (Alternator Coils Only)" [18 Ampere Stator], preceding. If stator tests OK, replace voltage regulator/rectifier.

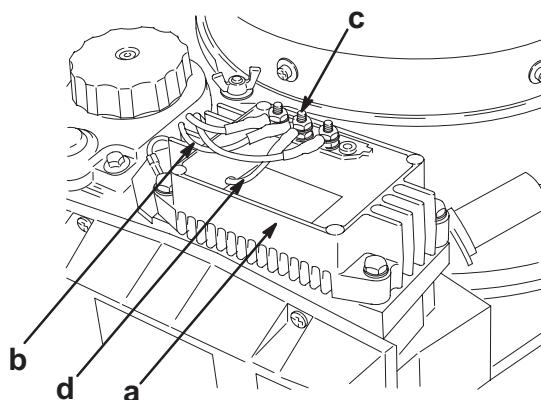

21619

a - Voltage Regulator/Rectifier c - Center Terminal
 b - RED Harness Wire d - RED Sense Lead

NOTE: If one or more of the 3 terminals on the terminal block are shorted to ground, the battery charging system output will be reduced.

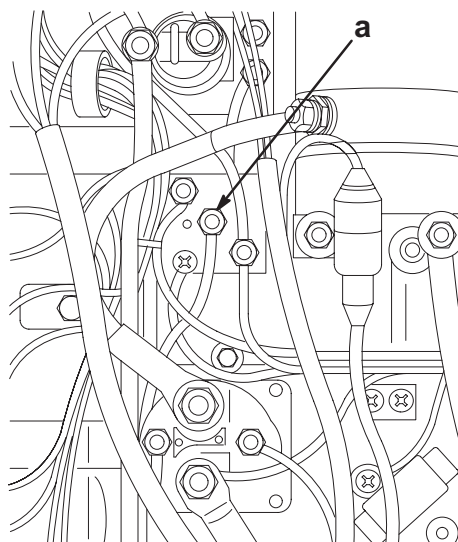

26001

a - Terminal Block



16 Ampere Alternator System Test

(SMALL VOLTAGE REGULATOR/RECTIFIER)

1. Check battery voltage at battery with engine running.
2. If battery voltage is above 14.5 volts, replace voltage regulator/rectifier. Check condition of battery as overcharging may damage battery.
3. If battery voltage is below 14.5 volts, charge battery; refer to "Charging a Discharged Battery", preceding. If battery can NOT be satisfactorily charged, replace battery.
4. If battery accepts a satisfactory charge, check battery voltage while cranking engine; refer to "Charging a Discharged Battery", preceding. If cranking voltage is not acceptable, replace battery.
5. If cranking voltage is acceptable, disconnect larger diameter Red wire from STARTER SOLENOID terminal.
6. Remove smaller diameter RED wire (SENSE LEAD) from STARTER SOLENOID terminal and connect to the POSITIVE (+) terminal of a 9 VOLT transistor battery. Ground the NEGATIVE (-) terminal of the 9 VOLT battery to the engine.
7. Connect RED (+) ammeter lead to larger diameter RED wire, and BLACK (-) ammeter lead to POSITIVE terminal on STARTER SOLENOID.
8. Secure wires away from flywheel.
9. With engine running at the indicated RPM's, the ammeter should indicate the following approximate amperes:

<u>RPM</u>	<u>AMPERES</u>
IDLE	2
1000	10
2000	17
3000	18

10. A reading of 18 amperes at 3000 RPM indicates the charging system is functioning properly. The battery is discharging due to the amperage draw on the system is greater than the amperage output of the engine charging system.
11. If ammeter reads less than 18 amperes, test the stator; refer to "Stator Ohms Test (Alternator Coils Only)", [18 Ampere Stator], preceding. If stator tests OK, replace voltage regulator/rectifier.

Optional 24 Amp Alternator System Test

(LARGE FINNED VOLTAGE REGULATOR/RECTIFIER)

1. Check battery voltage at battery with engine running.
2. If battery voltage is above 14.5 volts, replace voltage regulator/rectifier (a). Check condition of battery as overcharging may have damaged battery.
3. If battery voltage is below 14.5 volts, charge battery; refer to "Charging a Discharged Battery", preceding. If battery can NOT be satisfactorily charged, replace battery.
4. If battery accepts a satisfactory charge, check battery voltage while cranking engine; refer to "Charging a Discharged Battery", preceding. If cranking voltage is not acceptable, replace battery.
5. If cranking voltage is acceptable, disconnect RED harness wire (b) from terminal (c).
6. Secure RED wire (d) on terminal (c) using hex nut.
7. Connect RED (+) ammeter lead to terminal (c) and BLACK (-) ammeter lead to RED harness wire (b).
8. Secure wires away from flywheel.

IMPORTANT: For accurate test results the voltage at battery with engine running, in next step, must be 13.5 volts or less. It may be necessary to operate electrical accessories to drop voltage to 13.5 volts or less.

9. Run engine at 3000 RPM.
10. Meter should read 20 or more amperes.
11. If meter reads 20 or more amperes, this indicates the charging system is functioning properly and the battery is being discharged because the amperage draw on the system is greater than the amperage output of the system.
12. If meter reads less than 20 amperes, test the stator; refer to "Optional 24 Amp Stator (Alternator Coils) Amperes Output", following. If stator tests OK, replace voltage regulator rectifier (a).

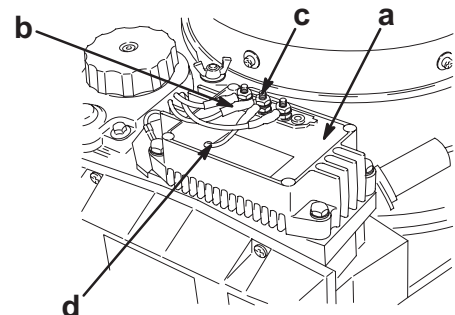



Tachometer Terminal Block (Design 1)

DESCRIPTION

Contains a diode which blocks high voltage AC pulses (180 VAC) coming from the stator and allows low voltage DC pulses (20-30 VDC) to pass through to be counted by the tachometer. This terminal block (with diode) is only used with large, finned type regulators. This block is BLACK in color.

⚠ WARNING

HIGH VOLTAGE is present at the tachometer block's stator side terminals, while the outboard is running. To avoid electrical shock, physical contact should not be made on these terminals or ANY IGNITION RELATED COMPONENT WHILE THE OUTBOARD IS RUNNING.

IMPORTANT: The following ohm test is used to determine the proper functioning of the diode located in the tachometer block. If the diode is OPEN (NO CONTINUITY IN EITHER DIRECTION), the tachometer will be inoperative.

TESTING TACHOMETER TERMINAL BLOCK (DESIGN 1)

With outboard NOT running, remove all leads from block. Using an ohmmeter, test block as shown, following. Continuity should be observed on the ohmmeter with the needle swinging in only ONE direction. NO CONTINUITY should be observed when test leads are reversed. If CONTINUITY is observed in BOTH directions or NO CONTINUITY is observed in either direction when leads are reversed, diode is defective and MUST BE REPLACED.

NOTE: There is only one diode located in the tachometer block. It may be located either between the center (TACH) terminal and the top (ALT) terminal or between the center (TACH) terminal and the lower (ALT) terminal.

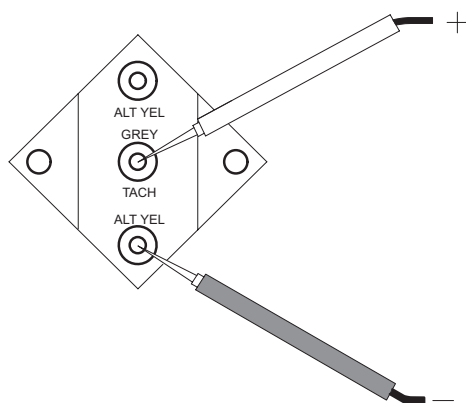

50644

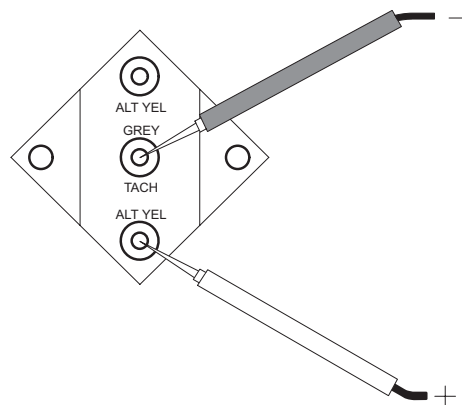

50644

Tachometer Terminal Block (Design 2)

DESCRIPTION

This block is a junction point for stator and tachometer signal wiring. It contains no electrical components. This block is LIGHT GREY in color and is to be used ONLY with small, non-finned voltage regulators. No test is required for this terminal block.

Tachometer Terminal Block (Design 1 and 2)

REMOVAL

1. Remove two YELLOW alternator wires from block.
2. Remove GREY tachometer wire from block.
3. Remove two attaching screws and remove diode block.

INSTALLATION

1. Secure diode block to powerhead with two screws. Torque screws to 30 lb. in. (3.4 N·m).
2. Attach two YELLOW wires to "ALT YEL" terminals.
3. Attach GREY wire to "GREY TACH" terminal.



3 Cylinder 16 and 24 Ampere Battery Charging Wiring Diagram

IMPORTANT: After electrical connections are made, coat all terminal connections using Quick-silver Liquid Neoprene (92-25711), to avoid corrosion.

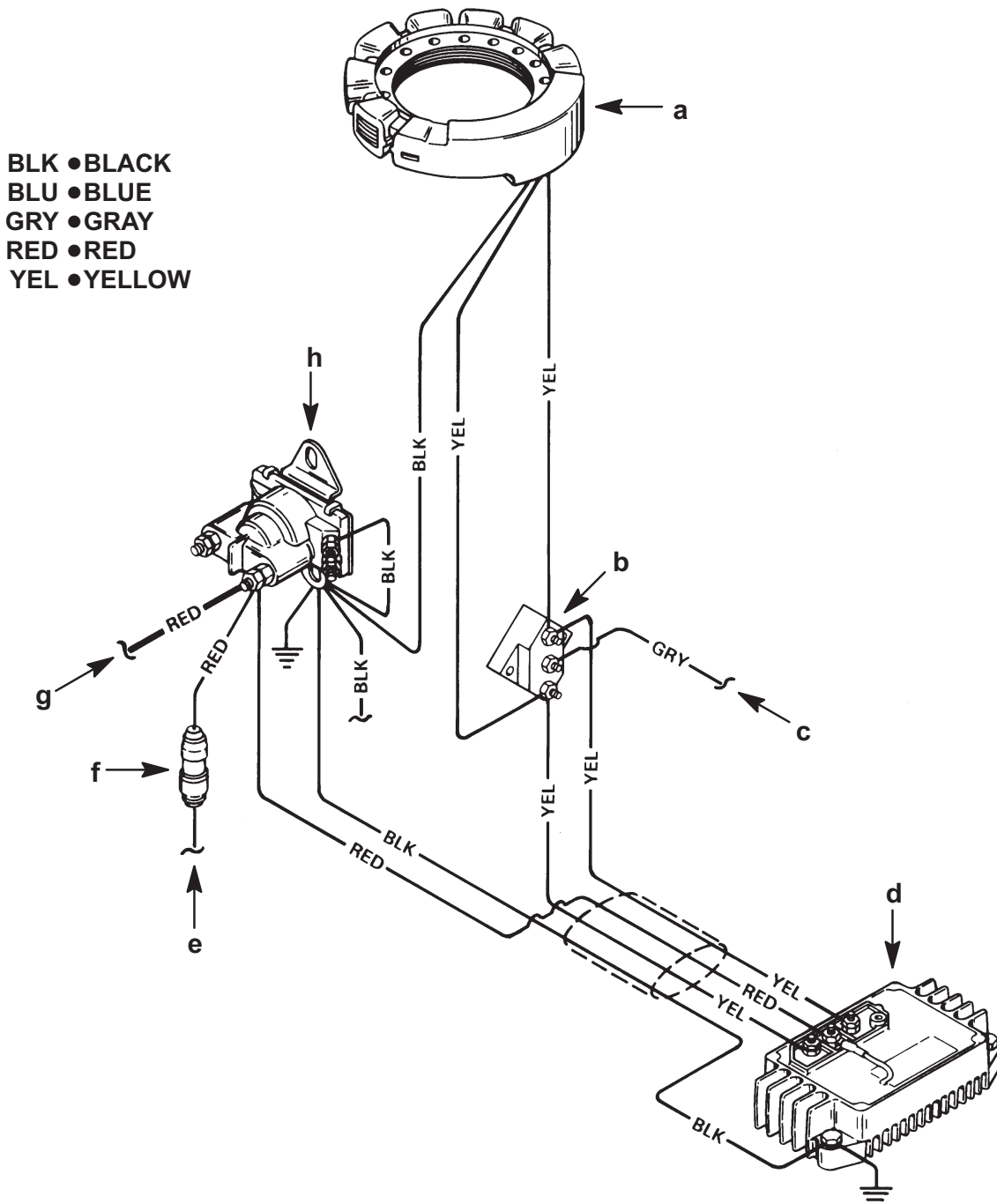

- a - Stator
- b - Terminal Block
- c - To Tachometer
- d - Voltage Regulator/Rectifier

- e - To Remote Control Harness
- f - 20 Ampere Fuse
- g - To Battery
- h - Starter Solenoid

50405



3 Cylinder 16 Ampere Battery Charging Wiring Diagram (with Small Voltage Regulator/Rectifier)

IMPORTANT: After electrical connections are made, coat all terminal connections using Quick-silver Liquid Neoprene (92-25711), to avoid corrosion.

BLK ●BLACK
BLU ●BLUE
GRY ●GRAY
RED ●RED
YEL ●YELLOW

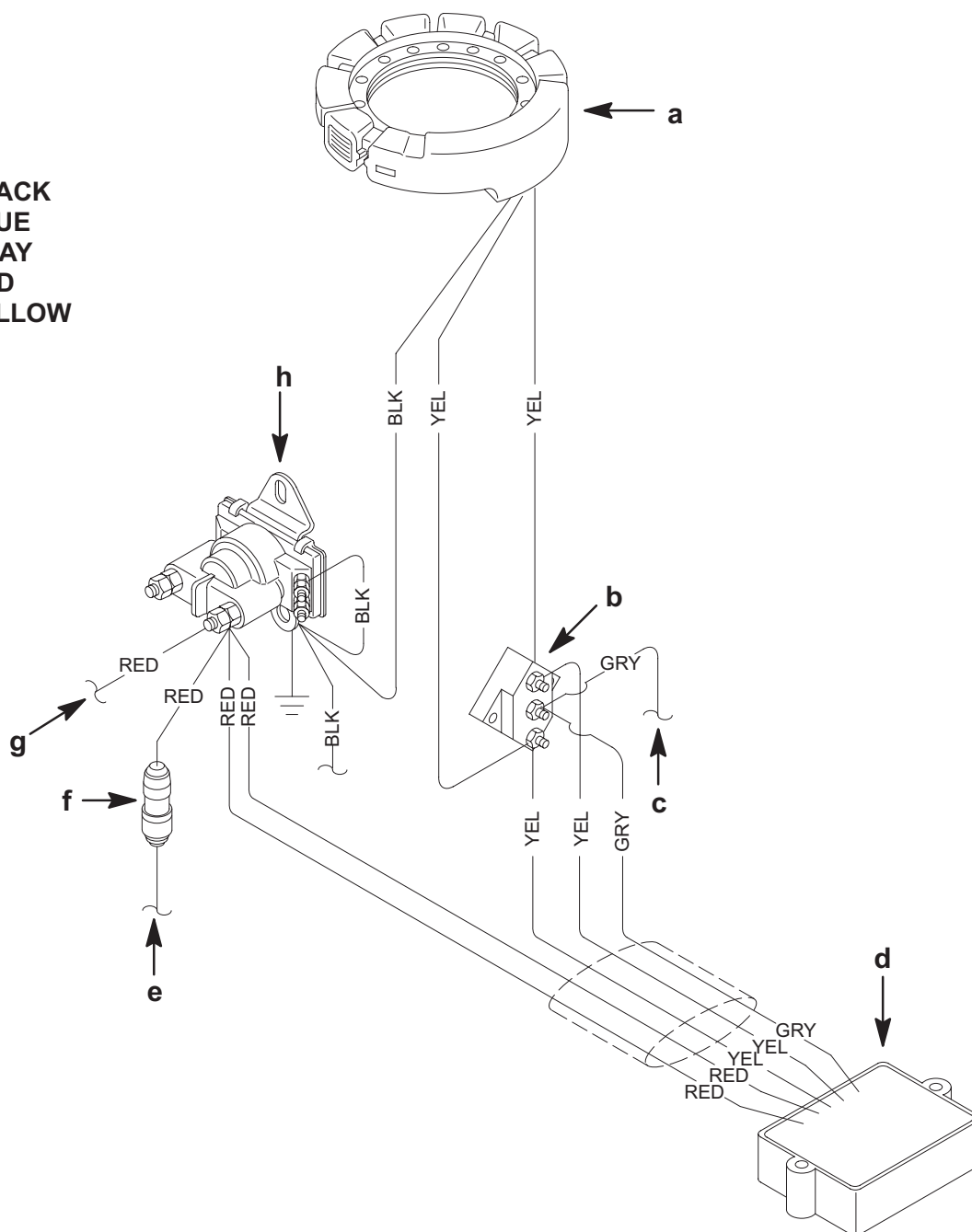

a - Stator
b - Terminal Block
c - To Tachometer
d - Voltage Regulator/Rectifier

e - To Remote Control Harness
f - 20 Ampere Fuse
g - Battery (+) Positive Terminal
h - Starter Solenoid

51000



4 Cylinder 16 and 24 Ampere Battery Charging Wiring Diagram

IMPORTANT: After electrical connections are made, coat all terminal connections using Quick-silver Liquid Neoprene (92-25711), to avoid corrosion.

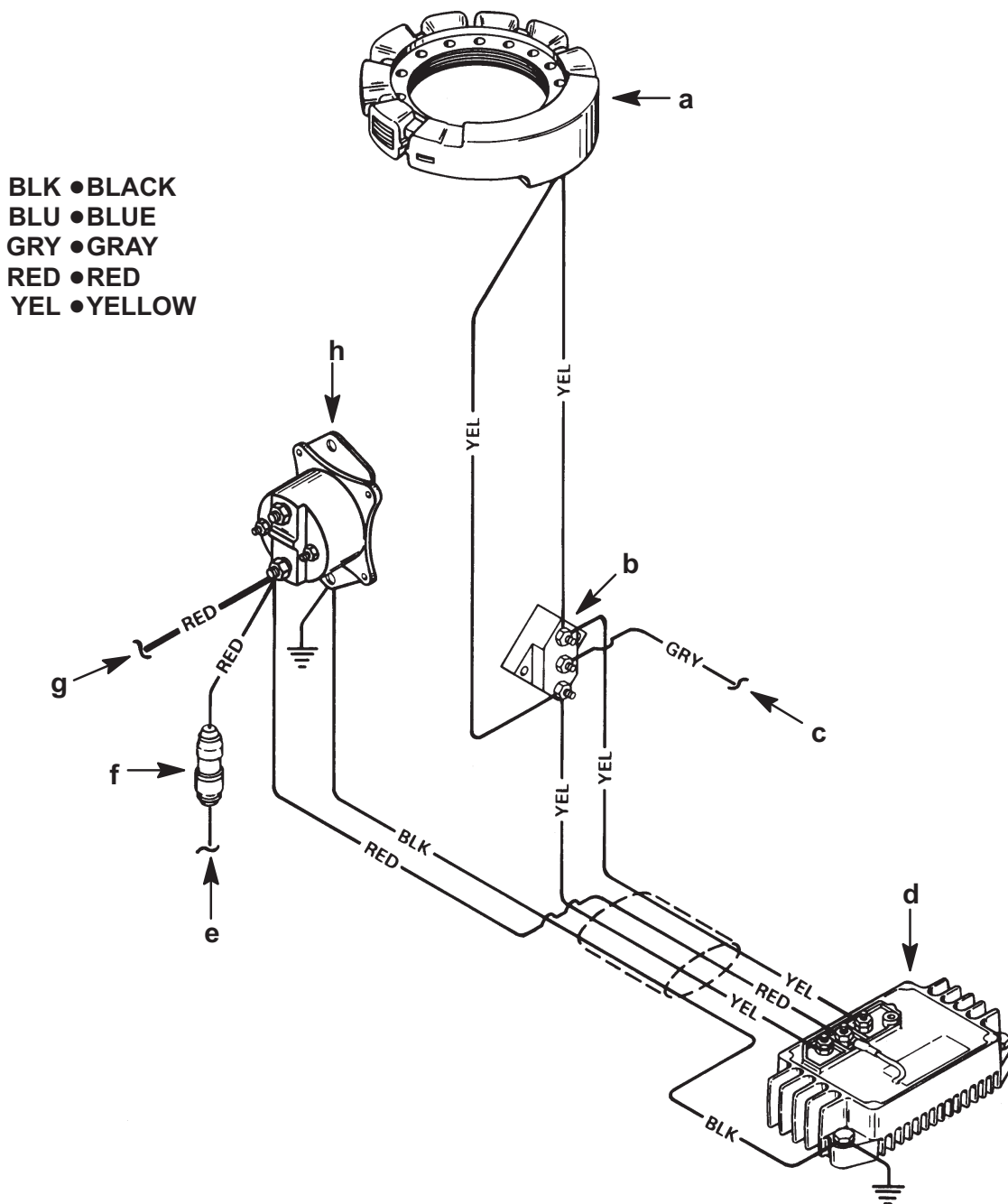

- a - Stator
- b - Terminal Block
- c - To Tachometer
- d - Voltage Regulator/Rectifier

- e - To Remote Control Harness
- f - 20 Ampere Fuse
- g - Battery (+) Positive Terminal
- h - Starter Solenoid

50406



3 Cylinder Battery Charging Diagram with Battery Isolator

IMPORTANT: After electrical connections are made, coat all terminal connections using Quick-silver Liquid Neoprene (92-25711), to avoid corrosion.

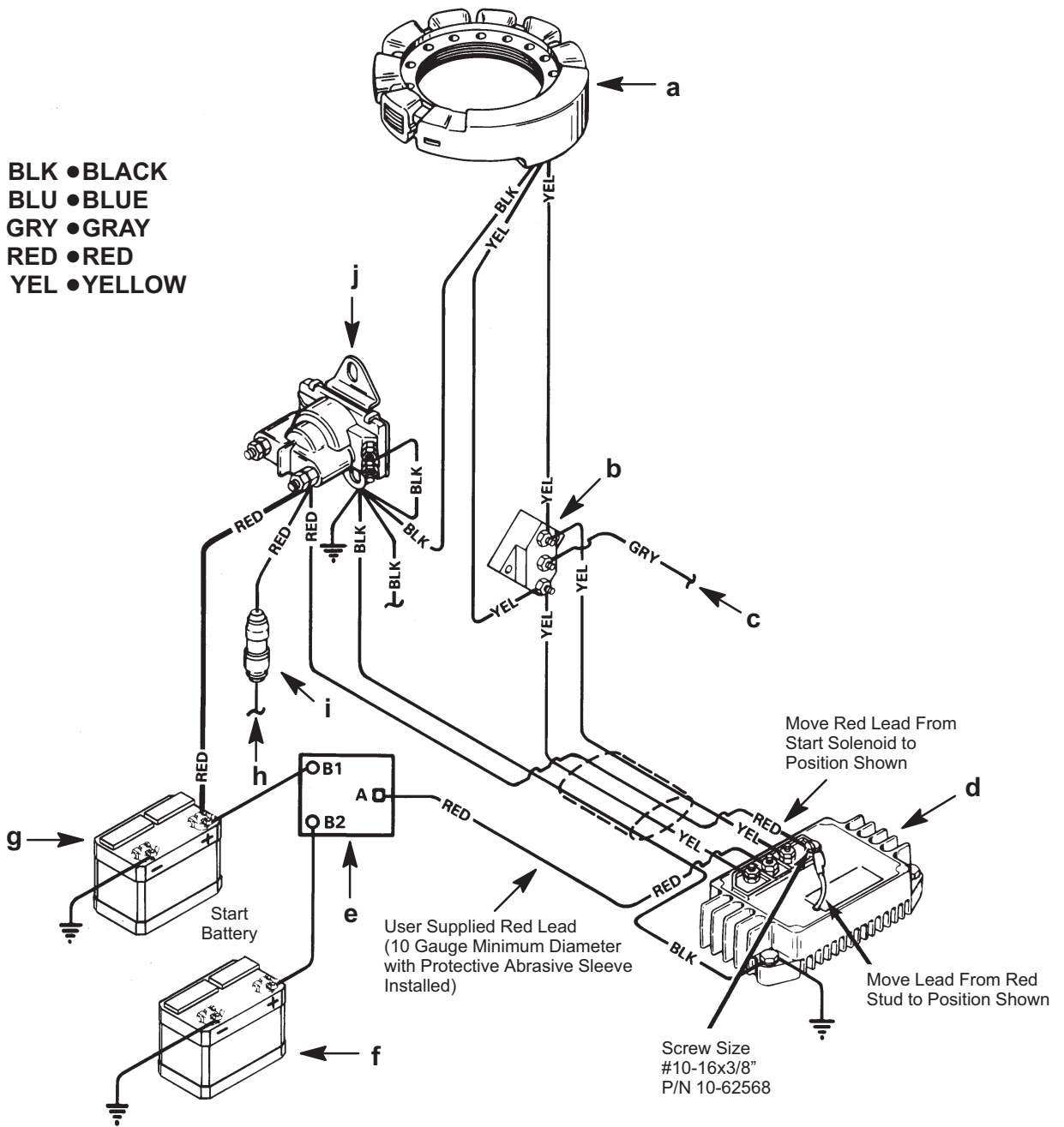

- a - Stator
- b - Terminal Block
- c - To Tachometer
- d - Voltage Regulator/Rectifier
- e - Battery Isolator
- f - Auxiliary Battery
- g - Start Battery
- h - To Remote Control Harness
- i - 20 Ampere Fuse
- j - Starter Solenoid

50403



3 Cylinder Battery Charging Diagram with Battery Isolator (Small Voltage Regulator)

IMPORTANT: After electrical connections are made, coat all terminal connections using Quick-silver Liquid Neoprene (92-25711), to avoid corrosion.

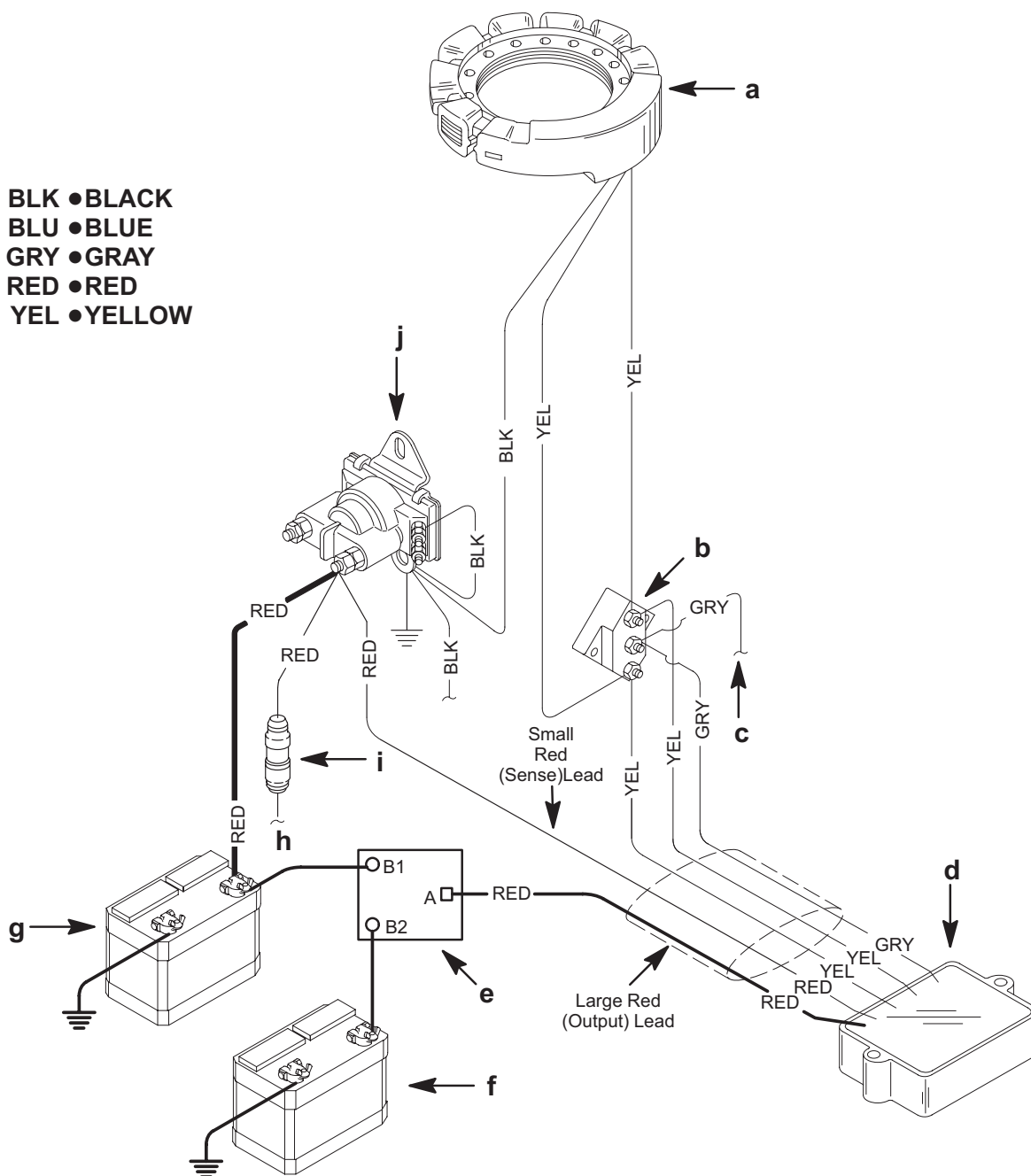

51051

- a - Stator
- b - Terminal Block
- c - To Tachometer
- d - Voltage Regulator/Rectifier
- e - Battery Isolator
- f - Auxiliary Battery
- g - Start Battery
- h - To Remote Control Harness
- i - 20 Ampere Fuse
- j - Starter Solenoid



4 Cylinder Battery Charging Diagram with Battery Isolator

IMPORTANT: After electrical connections are made, coat all terminal connections using Quick-silver Liquid Neoprene (92-25711), to avoid corrosion.

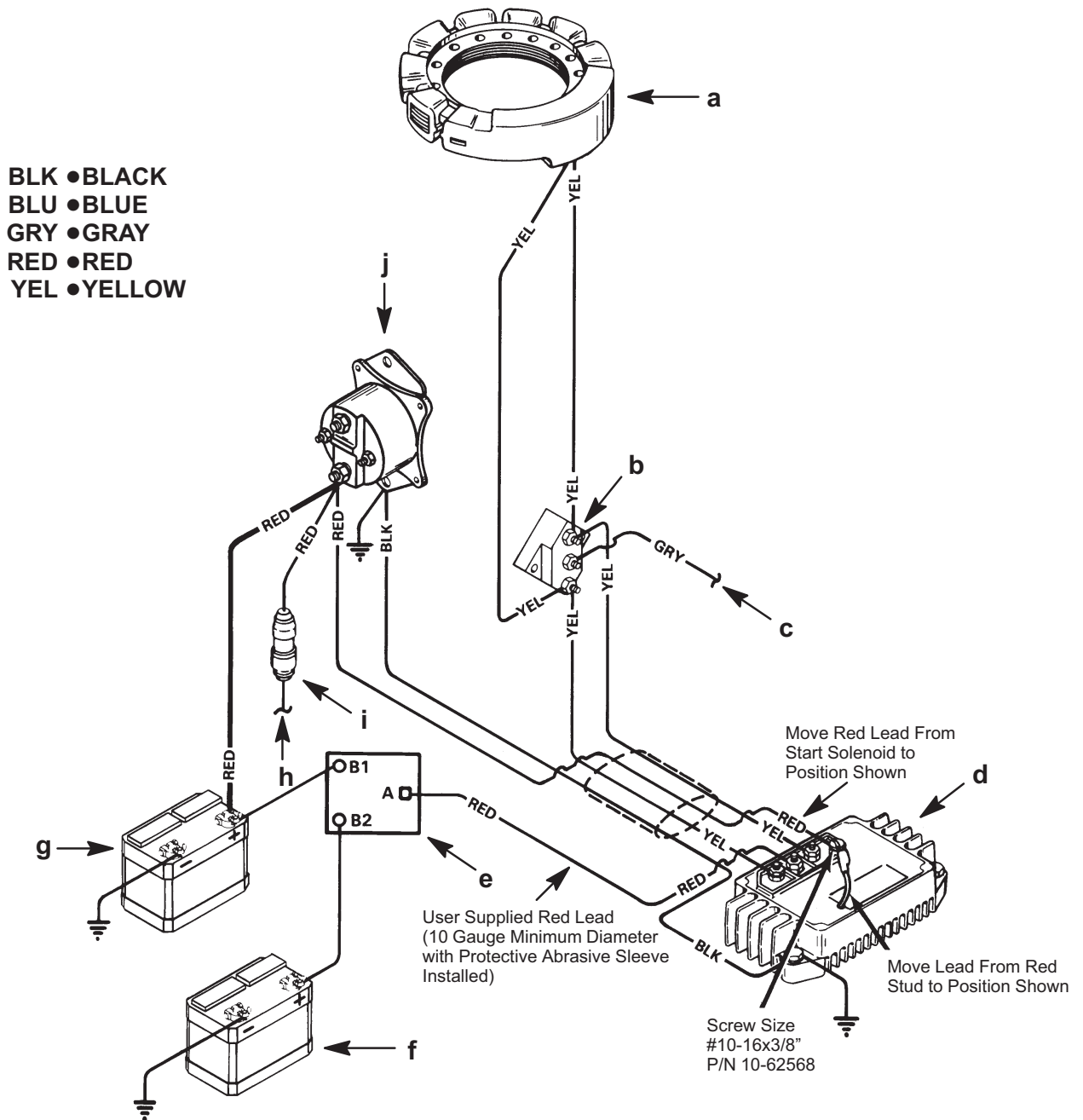

BLK ●BLACK
 BLU ●BLUE
 GRY ●GRAY
 RED ●RED
 YEL ●YELLOW

- a - Stator
- b - Terminal Block
- c - To Tachometer
- d - Voltage Regulator/Rectifier
- e - Battery Isolator
- f - Auxiliary Battery
- g - Start Battery
- h - To Remote Control Harness
- i - 20 Ampere Fuse
- j - Starter Solenoid

50404



4 Cylinder Battery Charging Diagram with Battery Isolator (Small Voltage Regulator)

IMPORTANT: After electrical connections are made, coat all terminal connections using Quick-silver Liquid Neoprene (92-25711), to avoid corrosion.

BLK •BLACK
BLU •BLUE
GRY •GRAY
RED •RED
YEL •YELLOW

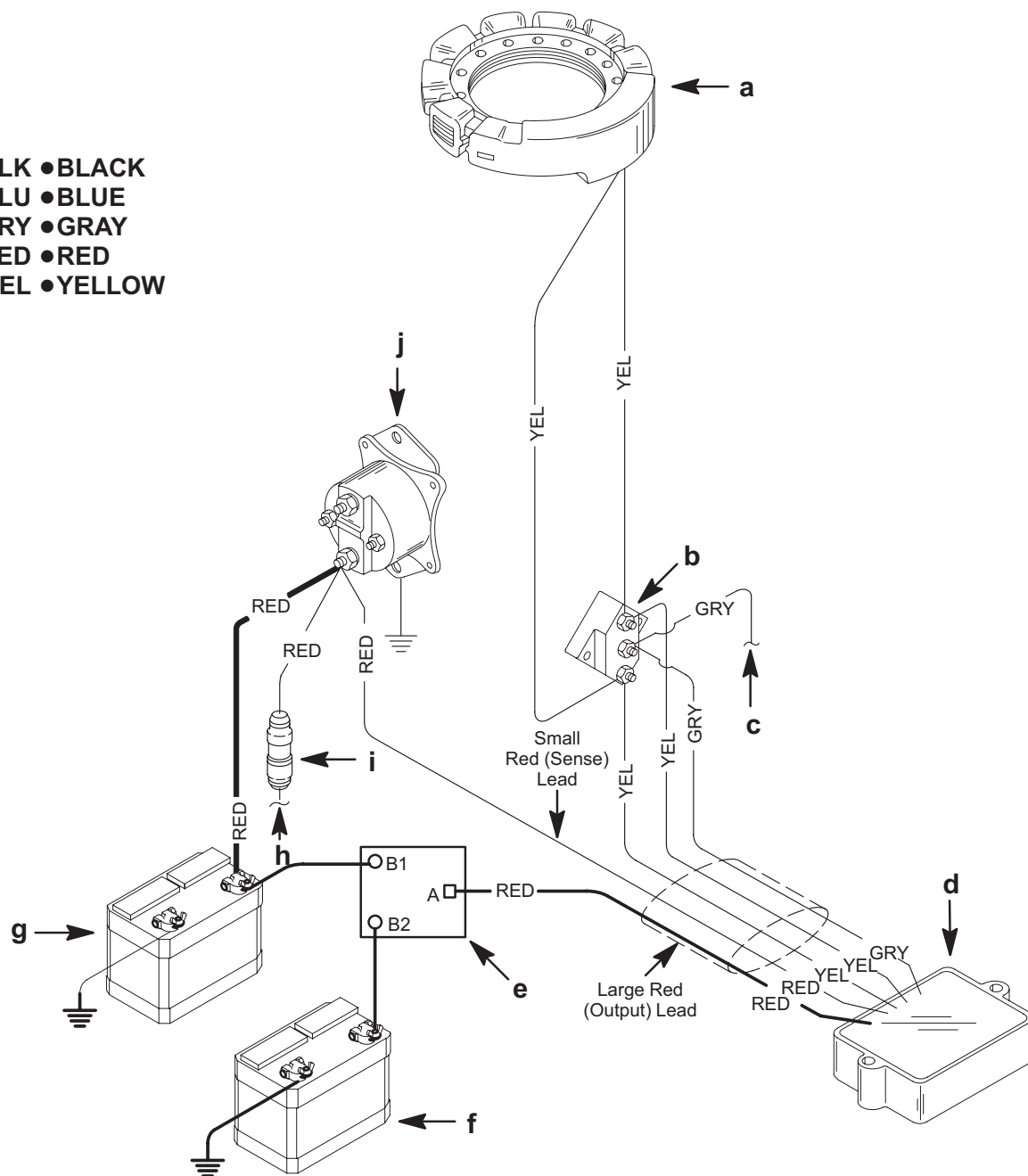

51050

- a - Stator
- b - Terminal Block
- c - To Tachometer
- d - Voltage Regulator/Rectifier
- e - Battery Isolator
- f - Auxiliary Battery
- g - Start Battery
- h - To Remote Control Harness
- i - 20 Ampere Fuse
- j - Starter Solenoid

