



JOHNSON PUMP

2007



# Global, yet Local

No matter whether you are an experienced boater looking for a replacement pump or a manufacturer looking for any pumps for your marine application, we are prepared to provide you with the support you need. And no matter where you work or live, access to our products, services, spare parts and support are never far away. In fact, you'll find Johnson Pump represented in every major industrial country of the world today and more than fifty nations altogether.

Johnson Pump is one of the world's leading manufacturers of pumps for marine use. For more than thirty years, Johnson Pump has been providing the boaters of the world with high quality, highly reliable pumps. Our extensive product range includes water pressure systems, bilge pumps, deckwash pumps, engine cooling pumps and more.

### Working with the Best

Thanks to our extensive marine pump experience, we know the boating industry well. This makes it possible for us to find pumping solutions that meet the specific needs of each customer.

That's why so many leading manufacturers of marine engines and recreational craft trust Johnson Pump to provide solutions for all their pumping needs.

### Quality a Trademark

Johnson Pump has built its international reputation on attention to quality in every detail of product development, production, and customer relations. You can count on us for constant improvement and further development in every aspect of our business dealings.



### Chandlery Display

In order to brand the Johnson Pump trademark more to the Boat Builders and the Aftermarket, we have made this chandlery display.

The easy, flexible and professional solution to display the products for the consumers.

### Chandlery Display

Part. No. 09-47072

Size 2300 mm x 900 mm x 500 mm.

Can be modified to 1500 mm x 900 mm x 500 mm.

## Contents

<b>General Johnson Pump</b>	<b>2-3</b>
<b>Pump programme</b>	<b>4-28</b>
Water pressure systems & wash down pumps	4-8
Submersible bilge pumps	9-12
Livewell aerating pumps	13
Bilge, deckwash and refuelling pumps	14-15
Bilge, waste and toilette handling	16-18
Circulating pumps	19
Toilets, Manual and electric	20-23
Self priming flexible impeller pumps	24-30
FB-5000 series	25
FB-8 series	26
FB-3000 series	27
Performance tables bronze impeller pumps	28
Engine cooling	29-30
<b>Impeller identification guide</b>	<b>31-38</b>

### ISO 9001 — of course

Since high quality has always been the trademark of Johnson Pump, quality assurance requirements are nothing new to us. Attention to qual-

ity has always been the foundation of what we do for a very simple reason: We have a commitment to meet the needs of our customers through continual product development and improvements both of human resources and production processes.



### ISO 14001 — because we care

Johnson Pump Marine is certified according to the demands set in ISO 14001, Environmental management system. We are doing our part to reduce any negative environmental impact from our production processes. We encourage our customers to continue our efforts by using our products in an environmentally sound manner on the waterways of the world.

**NEWS NEWS NEWS NEWS NEWS  
NEWS NEWS NEWS NEWS NEWS  
NEWS NEWS NEWS NEWS NEWS**

# WELCOME TO

[www.johnson-pump.com/jpmarine](http://www.johnson-pump.com/jpmarine)

## Find a Distributor near you

At our website [www.johnson-pump.com/jpmarine](http://www.johnson-pump.com/jpmarine) You can easily find a list of our world-wide distributors with address, phone and email-address so you can contact them for information about where to buy a Johnson Pump product.

## Products

You can look at our product range in and you can easily find basic technical information about our pumps so you can decide which products that is most suitable for your application.

## Publications

You can find several of our publications at our website such as this catalogue, instruction manuals etc that you can download as a pdf-files (requires Adobe Acrobat) and printout.



# JOHNSON PUMP

## Our Vision and Mission

### Our Vision

"A Johnson Pump in every boat and to become the number 1 supplier of pumps to the marine market world wide."

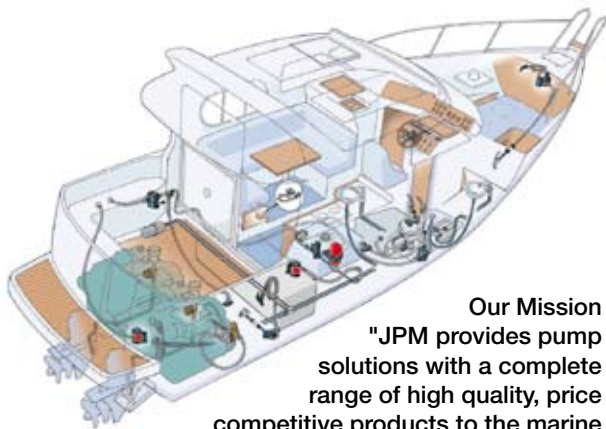

**Our Mission**  
"JPM provides pump solutions with a complete range of high quality, price competitive products to the marine industry world wide"

New updated Aqua Jet-series and a new WPS 3.5  
See page 5



Ultima Bilge, bilge pump with integrated switch  
See page 10



Johnson Pump Introduces AquaT™ Marine Toilets with accessories  
See page 20-23



# WATER PRESSURE SYSTEMS WASH DOWN PUMPS



CE marked according to following standards:

- EN55014: 1993/Radio disturbance
- ISO8846: 1990/Electrical devices – Protection against ignition of surrounding flammable gases
- ISO10133: 1994/Electrical systems – Extra-low voltage DC installations

Quiet and pulsation-free even at low speeds, the Aqua Jet five chamber diaphragm pump from Johnson Pump provides the perfect water pressure or deck wash solution for both small and medium sized leisure and commercial boats. Efficient and compact, Aqua Jet pumps are particularly suitable where low amperage and sound levels in relation to water flow are placed at a premium - such as in shower and galley applications. Integrated pressure switch for automatic operation.

## Fresh Water Handling

Components in Typical Water Pressure System

1. Water tank
2. Johnson Pump PUMProtector inlet strainer
3. Johnson Pump Aqua Jet water pressure pump
4. Battery
5. Fuse
6. Switch
7. Johnson Pump accumulator tank
8. Water heater
9. Check valve
10. Shut-off valve

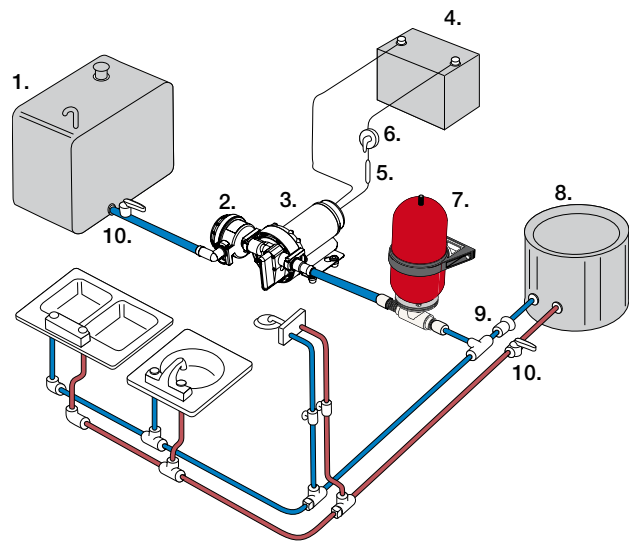

## Aqua Jet Water Pressure System WPS 2.9, WPS 3.5, WPS 4.0, WPS 5.2

The five chamber Aqua Jet WPS-series provide a reliable heart for small boat and recreational vehicle water pressure system. Compared to conventional three or four-chamber diaphragm pumps, the Aqua Jet demonstrates dramatically lower noise and water pulsation characteristics. Smooth and pulsation-free flow due to the five chamber design. It is recommended to install the WPS-pumps with an accumulator tank. Always use a PUMProtector inlet strainer before the pump intake, see page 8.

### Dimension & Weight

Model	WPS 2.9	WPS 3.5	WPS 4.0	WPS 5.2
Diaphragm	Santoprene	Santoprene	Santoprene	Santoprene
Valves	EPDM	EPDM	EPDM	EPDM
Body	PP/PPA	PP/PPA	PP	PP
Motor	90W	100W	100W	150W
Weight	1.6 kg/3.5 lbs	2 kg /4.5 lbs	2 kg /4.5 lbs	2 kg /4.5 lbs
Length	204 mm/8.02"	236,5 mm/9.31"	240 mm/9.46"	240 mm/9.46"
Widht	197 mm/7.76"	210 mm/8.25"	214 mm/8.42"	214 mm/8.42"
Height	110 mm/4.33"	116 mm/4.575"	110 mm/4.33"	110 mm/4.33"

**New!**

WPS 2.9



WPS 3.5

**New!**



WPS 4.0



WPS 5.2



### WPS 2.9

Order No	Description	Capacity	Pressure Cut In	Pressure Cut Off*	Fuze Size	Connection**
10-13405-03	Aqua Jet WPS 2.9 12V	11L/min / 2.9 GPM	1.7 bar / 24psi	2.8 bar / 41psi	10A	3/8" BSP / hose 1/2", 1/2" BSP / hose 3/4"
10-13405-04	Aqua Jet WPS 2.9 24V	11L/min / 2.9 GPM	1.7 bar / 24psi	2.8 bar / 41psi	5A	3/8" BSP / hose 1/2", 1/2" BSP / hose 3/4"

### WPS 3.5

Order No	Description	Capacity	Pressure Cut In	Pressure Cut Off*	Fuze Size	Connection**
10-13395-03	Aqua Jet WPS 3.5 12V	13L/min / 3.5 GPM	1.7 bar / 24psi	2.8 bar / 41psi	10A	3/8" BSP / hose 1/2", 1/2" BSP / hose 3/4"
10-13395-04	Aqua Jet WPS 3.5 24V	13L/min / 3.5 GPM	1.7 bar / 24psi	2.8 bar / 41psi	5A	3/8" BSP / hose 1/2", 1/2" BSP / hose 3/4"

### WPS 4.0

Order No	Description	Capacity	Pressure Cut In	Pressure Cut Off*	Fuze Size	Connection**
10-13406-03	Aqua Jet WPS 4.0 12V	15L/min / 4.0 GPM	1.7 bar / 24psi	2.8 bar / 41psi	10A	3/8" BSP / hose 1/2", 1/2" BSP / hose 3/4"
10-13406-04	Aqua Jet WPS 4.0 24V	15L/min / 4.0 GPM	1.7 bar / 24psi	2.8 bar / 41psi	5A	3/8" BSP / hose 1/2", 1/2" BSP / hose 3/4"

### WPS 5.2

Order No	Description	Capacity	Pressure Cut In	Pressure Cut Off*	Fuze Size	Connection**
10-13406-07	Aqua Jet WPS 5.2 12V	20L/min/ 5.2 GPM	1.7 bar / 24psi	2.8 bar / 41psi	15A	3/8" BSP / hose 1/2", 1/2" BSP / hose 3/4"
10-13406-08	Aqua Jet WPS 5.2 24V	20L/min/ 5.2 GPM	1.7 bar / 24psi	2.8 bar / 41psi	8A	3/8" BSP / hose 1/2", 1/2" BSP / hose 3/4"

\*Cut off pressure 2.1 bar/30 psi and 1.4 bar/20 psi available on request

\*\* NPT-connection available on request



**New!**

### WPS 3.5

*Fitted with a built-in pulsation dampening by-pass to control unwanted cycling and noise*

## Aqua Jet Uno Water Pressure System

Medium demand unit with a single Aqua Jet WPS capacity 13 L/min or 20 L/min fixed on a base with PUMProtector inlet strainer and a pre-pressured 2 litres accumulator tank.



Order No	Description	Capacity	Cut-off pressure*	Fuze size	Connection
10-13408-01	WPS Uno 3.5 12V	13L/min - 3.5GPM	2.8 bar/41 psi	10A	3/4" hose
10-13408-02	WPS Uno 3.5 24V	13L/min - 3.5GPM	2.8 bar/41 psi	5A	3/4" hose
10-13408-03	WPS Uno 5.2 12V	20L/min - 5.2GPM	2.8 bar/41 psi	15A	3/4" hose
10-13408-04	WPS Uno 5.2 24V	20L/min - 5.2GPM	2.8 bar/41 psi	8A	3/4" hose

\*Cut off pressure 2.1 bar/30 psi and 1.4 bar/20 psi available on request

## Aqua Jet Duo Water Pressure System

High demand unit with two parallel-connected Aqua Jet WPS capacity 40 L/min fixed on a base with PUMProtector inlet strainers and a pre-pressured 2 litres accumulator tank.



Order No	Description	Capacity	Cut-off pressure	Fuze size	Connection
10-13409-01	WPS Duo 10.4 12V	40L/min - 10.4GPM	2.8 bar/41 psi	25A	3/4" hose
10-13409-02	WPS Duo 10.4 24V	40L/min - 10.4GPM	2.8 bar/41 psi	15A	3/4" hose



## Aqua Jet Uno Max

Medium demand unit with a single Aqua Jet WPS with capacity 11 or 13 L/min fixed on a wooden panel for easy and efficient installation. The unit includes a PUMProtector inlet strainer and a two liters pre-pressurized accumulator tank.

*Replaces Jabsco Ultra Max.*

Order No	Description	Capacity	Cut-off pressure	Fuze size	Connection
10-13410-01	WPS Uno-Max 2.9 12V	11L/min - 2.9GPM	2.8 bar/41 psi	10A	1/2" hose
10-13410-02	WPS Uno-Max 2.9 24V	11L/min - 2.9GPM	2.8 bar/41 psi	5A	1/2" hose
10-13411-01	WPS Uno-Max 3.5 12V	13L/min - 3.5GPM	2.8 bar/41 psi	10A	1/2" hose
10-13411-02	WPS Uno-Max 3.5 24V	13L/min - 3.5GPM	2.8 bar/41 psi	5A	1/2" hose

## Aqua Jet Flow Master 5.0 Water Pressure System

The Flow Master 5.0 is a five chamber positive displacement diaphragm pump that is an ideal choice for pressurizing water in a closed system such as that found in a boat or recreational vehicles. The digital controller adjusts water flow as the demand is increased and decreased while maintaining a very smooth flow. The unique variable flow feature of the Flow Master pump allows the pump to be mounted without an accumulator tank and still maintain an even flow regardless if one or multiple taps are being used.

**Dimensions:** 239 mm long x 209 mm wide x 113 mm high  
**Weight:** 2 kg  
**Motor:** WPS 5.0 – 150 W, 12/24V DC  
 (with built-in thermal protection)  
**Body:** Nylon/Polypropylene  
**Valves:** Santoprene/EPDM  
**Diaphragm:** Santoprene

**Unique variable flow feature**



Order No	Description	Capacity	Cut-off pressure	Fuse size	Connection
10-13329-03	WPS FM 5.0 12V	19L/min – 5GPM	3.5 bar/50 psi	15 A	3/8" BSP / hose 1/2", 1/2" BSP / hose 3/4"
10-13329-04	WPS FM 5.0 24V	19L/min – 5GPM	3.5 bar/50 psi	8 A	3/8" BSP / hose 1/2", 1/2" BSP / hose 3/4"

## Aqua Jet Wash Down Pumps 3.5 & 5.2

As a wash down pump, the Aqua Jet offers much higher pressures than competitive models, making clean-up faster and easier than ever before. Complete with trigger nozzle, PUMProtector inlet strainer and hose connections for 1/2" hose. Both BSP and NPT connection included in package

**Dimensions** See WPS 2.9, WPS 3.5 and & weight: WPS 5.2 on page 5  
**Motor:** WD 2.9 - 90 W, 12/24V DC  
 WD 3.5 - 130 W, 12/24V DC  
 WD 5.2 - 185 W, 12/24V DC  
 (with built-in thermal protection)  
**Body:** PA  
**Valves:** Nitrile  
**Diaphragm:** Santoprene

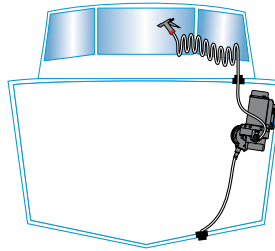

Order No	Description	Capacity	Cut-off-pressure	Fuze size	Connection
10-24728-03	WD 2.9 12V	11L/min - 2.9GPM	2.8 bar/ 41 psi	10A	3/8" BSP / hose 1/2"
10-24728-04	WD 2.9 24V	11L/min - 2.9GPM	2.8 bar/ 41 psi	5A	3/8" BSP / hose 1/2"
10-13407-03	WD 3.5 12V	13L/min - 3.5GPM	5 bar/ 70 psi	15A	3/8" BSP / hose 1/2"
10-13407-04	WD 3.5 24V	13L/min - 3.5GPM	5 bar/ 70 psi	8A	3/8" BSP / hose 1/2"
10-13407-07	WD 5.2 12V	20L/min - 5.2GPM	5 bar/ 70 psi	20A	3/8" BSP / hose 1/2"
10-13407-08	WD 5.2 24V	20L/min - 5.2GPM	5 bar/ 70 psi	10A	3/8" BSP / hose 1/2"

## Aqua Jet Wash Down Pump Kit 5.2

New 20 l/min (5.2 GPM) wash down kit conveniently includes a high capacity Aqua Jet WD 5.2, 5 bar (70 psi), PUMProtector inlet strainer, spray nozzle, bulk head fitting with valve, 7.5 meters (25') of coiled wash down hose and an illuminated panel switch all in one package. Aqua Jet wash down pump kit makes it easy to add a wash down pump to any boat.

Order No	Description
32-64534	Aqua Jet 5.2 Wash Down Pump Kit 12 V
32-64534-24	Aqua Jet 5.2 Wash Down Pump Kit 24 V

Accessories available

Order No.	Description
09-10616	Bulkhead fitting 3/4" hose



## PUMProtector™ Strainer

All wash-down and water-system strainers are designed to prevent debris and other particles from damaging the pump or passing through the system to the final outlet. The new PUMProtector™ inlet and universal strainers from Johnson Pump are also designed to make your life simpler.

Both of these new strainers feature transparent covers for simple inspection, a wide variety of KlickTite™ port connectors for simple installation and removal, and high quality materials for simple maintenance. The new design and connectors make it possible to remove the entire unit for thorough cleaning wherever it's most convenient. We recommend 40 mesh for water pressure and wash down pumps and 20 mesh for general purpose pumps

### Inlet and Universal Strainers

<b>Materials</b>	<b>Strainer</b>	Polyamide 66, black
	<b>Cover</b>	Acrylic, clear
	<b>Screen</b>	Stainless steel, 20 and 40 mesh
	<b>O-rings</b>	Silicone and EPDM

**Max. liquid temperature** +50°C / +120°F

**Max. temperature for drinking water** +30°C / +85°F

**Diameter** 80 mm / 3.15"

**Height** 60 mm / 2.35"

**Port options** See illustration

**Weight** 0.15 kg / 0.33 lbs

**Mesh size** 20 or 40 mesh



### Universal Strainer

<b>Order No</b>	<b>Mesh</b>	<b>KlickTite™ Connector</b>
09-24652-01	40	2x 1/2" hose / 3/8" BSP 2x 3/4" hose / 1/2" BSP
09-24652-03	20	2x 1/2" hose / 3/8" BSP 2x 3/4" hose / 1/2" BSP

### Inlet Strainer

<b>Order No</b>	<b>Mesh</b>	<b>KlickTite™ Connector</b>
09-24653-01	40	Built-in KlickTite™ 1x 1/2" hose / 3/8" BSP 1x 3/4" hose / 1/2" BSP



09-24653-03	40	Built-in KlickTite™ Bulk pack w/o connectors
-------------	----	---

## KlickTite™ port connectors

KlickTite™ port connectors are available for virtually any hose diameter and make it possible to remove the entire unit for thorough cleaning wherever it's most convenient. They also make it possible to drain the system quickly for effortless winterizing without the use of any tools.

<b>Order No.</b>	<b>2 pcs/package</b>
09-46783	2 x 1/2" hose and 3/8" BSP
09-46784	2 x 3/4" hose and 1/2" BSP
09-46939	2 x 90°, 3/4" hose
09-47087	2 x 90°, 1/2" BSP
09-46938	2 x 90°, 1/2" hose
09-47026	2 x 90°, 3/8" BSP
09-47094	2 x Garden hose adapter
09-47096	2 x 3/8" BSP
09-47098	2 x 1/2" BSP

<b>Order No.</b>	<b>1 piece/package</b>
09-47092	1 x T-connection, 3/4" barb

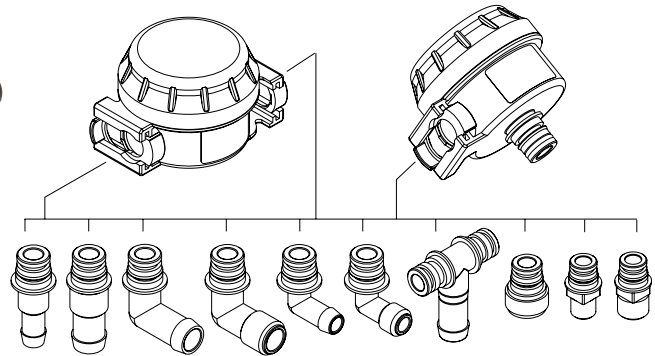

## Inline strainer

**Total length:** 230 mm  
**Diameter:** 32 mm



<b>Order No.</b>	<b>Description</b>
48-80035	Inline strainer, 1/2" hose
48-80036	Inline strainer, 3/4" hose
48-80037	Inline strainer, 3/4" BSP

## Adapter kit quick connection to hose

In order to improve operation of the Aqua Jet pumps together with any type of quick connect tubing, Johnson Pump recommends a piece of flexible hose on the inlet and outlet of the pump. In order to facilitate these installations Johnson Pump offers this Adapter kit from either 15 mm tube to 1/2" hose or 22 mm tube to 3/4" hose.

<b>Order No.</b>	<b>Description</b>
09-36079-01	Adapter 15 mm quick conn 1/2" hose
09-36079-02	Adapter 22 mm quick conn 3/4" hose



## Accumulator tank

The use of an accumulator tank is recommended to ensure effective and reliable system function. With an accumulator tank incorporated in the system, the intervals between cut-in and cut-out will be longer when only small amounts of water are drawn off. Less wear and tear on the pump with fewer starts and stops. Pre-pressured at 0.8 bar.

<b>Volume</b>	2 l
<b>Port connections:</b>	1/2" or 3/4" hose
<b>Height:</b>	315 mm
<b>Diameter:</b>	160 mm
<b>Weight:</b>	1,2 kg

<b>Order No.</b>	<b>Description</b>
09-46839-01	1/2" hose connection
09-46839-02	3/4" hose connection



# HEAVY DUTY SUBMERSIBLE BILGE PUMPS



CE marked according to following standards:

- EN55014: 1993/Radio disturbance
- ISO8846: Small Craft – Electrical devices
  - Protection against ignition of surrounding flammable gases
- ISO8849: Small craft – Electrically operated bilge pumps
- ISO10133: Small Craft – Electrical systems
  - Extra-low voltage DC installations

Choose the Johnson Pump range of submersible bilge pumps and you will not be disappointed. With a variety of mounting options, capacities of 30 to 252 L/min and clip on optional automatic switch. Johnson Pump submersible pumps can handle most of the bilge pump applications. Heavy duty motors with stainless steel (SS2343) shaft and tough thermoplastic bodies provide for a long pump life. With the Johnson Pump automatic switch installed, the pump automatically comes on when there is water in the bilge and shuts off when it is dry. Submersible bilge pumps are not self-priming and must be installed in the deepest part of the bilge.

## Submersible Bilge Pumps

The most economic bilge pump offering low cost and easy installation. Should be mounted in the lowest point in the bilge. The Cartridge pumps, L450-L750 as well as L1600 -L4000, can be combined with Johnson Pump new Ultima switch for fully automatic bilge pumping operation. The series of Ultima Combo L450 UC-L750 UC is equipped with an Ultima switch. By using Johnson Pump bilge pump control panel, the pump can also be run manually. The Johnson Pump series of submersible bilge pumps offer a wide range with various flows.

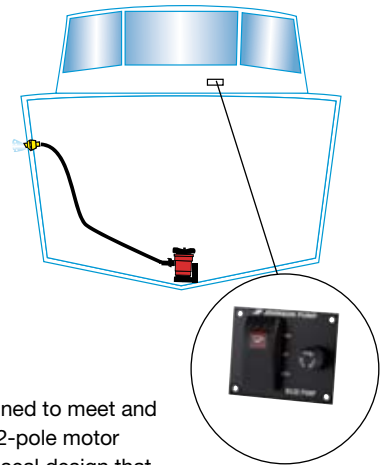

## L-Series L1600-L4000 – 12/24 V DC

The best choice when you are looking for a high performance, heavy duty bilge pump that is designed to meet and exceed the tough demands of commercial and recreational duty. This pump has a liquid cooled, 12-pole motor with double ball bearings for extended service life. The L2200 motor is sealed off by a mechanical seal design that eliminates shaft wear and allows for service and replacement, while the L1600 model has lipseal. The impeller is carefully designed and tested to maximize head and flow.

The L4000 high capacity, heavy duty bilge pump has been developed by Johnson Pump as the premier pump in our submersible bilge pump range. Featuring a robust motor design, mechanical shaft seal, high impact ABS plastic and unique threaded port design, the L4000 will out perform all other comparable pumps on the market. Universal base plate and a choice of 1.½” or 2” ports makes for a simple installation. All L1600-L4000 pumps include a removable check valve.

**Now with removable check valve**



	L1600	L2200	L4000
Shaft:	SS2343	SS2343	SS2343
Wire size:	1.5 mm <sup>2</sup>	1.5 mm <sup>2</sup>	1.5 mm <sup>2</sup>
Max dia:	108 mm	108 mm	121 mm
Max height:	149 mm	177 mm	216 mm
Weight:	1.3 kg	2.7 kg	2.45 kg

Order No.	Pump model	Capacity 1.0 m head (13.6 V/27 V)	Capacity straight (13.6 V/27 V)	Amperage:	Fuse size:	Hose size:
32-1600-01	L1600 12 V	98L/min - 1550 GPH	100L/min - 1600 GPH	7 A	10 A	1.1/8" and 1.1/4"
32-1600-02	L1600 24 V	98L/min - 1550 GPH	100L/min - 1600 GPH	3.5 A	6 A	1.1/8" and 1.1/4"
32-2200-01	L2200 12 V	120L/min - 1900GPH	130L/min - 2060 GPH	7.5 A	12 A	1.1/8" and 1.1/4"
32-2200-02	L2200 24 V	120L/min - 1900GPH	130L/min - 2060 GPH	4.5 A	6 A	1.1/8" and 1.1/4"
32-4000-01	L4000 12 V	164 L/min - 2600 GPH	252 L/min - 4000 GPH	15 A	25 A	1.1/2" and 2"
32-4000-02	L4000 24 V	164 L/min - 2600 GPH	252 L/min - 4000 GPH	7.5 A	15 A	1.1/2" and 2"

## Ultima Bilge™

UltimaBilge™ Pumps are the latest addition to the Johnson Pump lineup. Integration of the patented Ultima “field effect” sensing technology into the bilge pump body creates a sleek, reliable compact, unit ready to install and run for years and years of unerring service. Available in 600-800-1000-1250 GPH versions. Voltage 12 V DC. For UltimaBilge™ 600GPH-100GPH, we have easy-to-install Dura-Port discharge ports to eliminate stress cracking caused by over-tightened hose clamps. These pumps will be delivered including both a straight and a 90° smooth elbow Dura-Port. For UltimaBilge™ 1250GPH we include threaded 1.1/4" & 1.1/8" discharge port. All version are delivered with a removable check valve.

Dimensions: L=142 mm, W=82 mm, H=105 mm

Weight: 0.66 kg



**New!**

Order No.	Pump model		Capacity		Amperage:	Fuse size:	Hose size:
			1.0 m head (13.6 V)	Capacity straight (13.6 V)			
32-47258	600 GPH	12V	32 L/min - 500 GPH	38 L/min - 600 GPH	2.5 A	5 A	3/4"
32-47259	800 GPH	12V	38 L/min - 600 GPH	51 L/min - 800 GPH	3 A	5 A	3/4"
32-47260	1000 GPH	12V	44 L/min - 700 GPH	64 L/min - 1000 GPH	3.2 A	5 A	3/4"
32-47261	1250 GPH	12V	51 L/min - 800 GPH	79 L/min - 1250 GPH	3 A	5 A	1.1/8" and 1.1/4"

## Cartridge L450, L550, L650, L750

for 12 V DC or 24 V DC for L650 and L750 incorporate some of the most advanced features in the industry, features developed from service in a wide variety of uses including racing, cruising, sport fishing, and demanding commercial duties. For L450, L550, and L650, we have improved the design with easy-to-install Dura-Port discharge ports to eliminate stress cracking caused by over-tightened hose clamps. The pumps will be delivered including both a straight and a 90° smooth elbow Dura-Port. as well as a removable check valve.

Max dia: 70 mm  
 Max height: 112 mm  
 Weight:  
 L450, L550, L650 0.27 kg  
 L750 0.32 kg

**L650 & L750 also available in 24V**



Order No.	Pump model		Capacity		Amperage:	Fuse size:	Hose size:
			1.0 m head (13.6 V)	Capacity straight (13.6 V)			
32-1450-01	L450 - 700 GPH	12V	38 L/min - 601 GPH	49 L/min - 778 GPH	2.5 A	3 A	3/4"
32-1550-01	L550 - 750 GPH	12V	45 L/min - 713 GPH	56 L/min - 884 GPH	3 A	5 A	3/4"
32-1650-01	L650 - 850 GPH	12V	53 L/min - 844 GPH	61 L/min - 972 GPH	3.2 A	5 A	3/4"
32-1650-01-24	L650 - 850 GPH	24V	53 L/min - 844 GPH	61 L/min - 972 GPH	2 A	3 A	3/4"
32-1750-01*	L750 - 1050 GPH	12V	60 L/min - 952 GPH	73 L/min - 1150 GPH	3 A	5 A	1.1/8"
32-1750-01-24*	L750 - 1050 GPH	24V	60 L/min - 952 GPH	73 L/min - 1150 GPH	2 A	3 A	1.1/8"

\*) Do not include Dura-Port connection

## Ultima Combo

The Ultima Combo combines the line of Cartridge Bilge Pumps with automatic operation. The pump is equipped with the new Ultima switch. Voltage 12 V DC as well as 24 V DC for L650 UC and L750 UC. For L450 UC - L650 UC, we have easy-to-install Dura-Port discharge ports to eliminate stress cracking caused by over-tightened hose clamps. The pumps will be delivered including both a straight and a 90° smooth elbow Dura-Port as well as a removable check valve.



Max dia: 75x100 mm  
 Max height: 112 mm  
 Weight:  
 L450 UC - L650 UC 0.40 kg  
 L750 UC 0.45 kg

**L650 & L750 also available in 24V**

Order No.	Pump model		Capacity		Amperage:	Fuse size:	Hose size:
			1.0 m head (13.6 V)	Capacity straight (13.6 V)			
32-1450UC-01	L450 UC - 700 GPH	12V	38 L/min - 601 GPH	49 L/min - 778 GPH	2.5 A	3 A	3/4"
32-1550UC-01	L550 UC - 750 GPH	12V	45 L/min - 713 GPH	56 L/min - 884 GPH	3 A	5 A	3/4"
32-1650UC-01	L650 UC - 850 GPH	12V	53 L/min - 844 GPH	61 L/min - 972 GPH	3.2 A	5 A	3/4"
32-1650UC-01-24	L650 UC - 850 GPH	24V	53 L/min - 844 GPH	61 L/min - 972 GPH	2 A	3 A	3/4"
32-1750UC-01*	L750 UC - 1050 GPH	12V	60 L/min - 952 GPH	73 L/min - 1150 GPH	3 A	5 A	1.1/8"
32-1750UC-01-24*	L750 UC - 1050 GPH	24V	60 L/min - 952 GPH	73 L/min - 1150 GPH	2 A	3 A	1.1/8"

\*) Do not include Dura-Port connection

## Multiple Port Shower Sump

This compact shower sump system is designed to meet the higher demands from today's boating industry where more and more equipment is used. This also includes the fresh water system onboard and involves showers, dish-washing machines, galley's sink etc. The shower sump turns on/off automatically using our Ultima switch technology and has multiple inlet ports for handling waste water from more than one tapping point. Equipped with a check valve on the outlet avoids water coming back into the tank. The tank has a tight-fitting lid to minimize splashing and odors. To further aid in cleaning, the system includes a filter mesh that removes with ease.

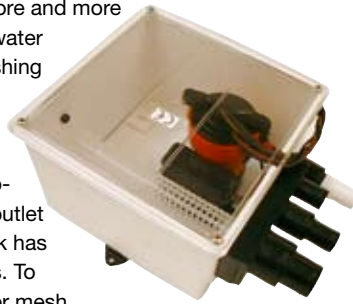

Capacity, straight (13.6 V): 61 L/min  
 Capacity 1.0 m head (13.6 V): 53 L/min  
 Voltage: 12 V / 24 V DC  
 Amperage: 3.4 A / 2 A  
 Fuse size: 5 A / 3 A  
 Intake hose: 1x3/4", 1x3/4" or 1x1", 1x1.1/8" or 1x1.1/2"  
 Discharge hose: 3/4"  
 Max dia: 290x210 mm  
 Max height: 145 mm  
 Weight: 0.95 kg

Order No.  
 32-57151-01 12V  
 32-57151-02 24V

## Bilge Alert™

High water alarm featuring new digital technology using the patented Mirus field effect cell. Totally sealed fluid detectors are never in contact with water, will not corrode and are not affected by oil or debris. Bilge Alert detects water and sends a signal (8 seconds delay) to the alarm and switch conveniently mounted on a panel. Three way rocker switch allows alarm to be tested, turned off and armed.



## Automatic Switch AS888

For full automatic bilge pumping operation, connect the automatic switch to your bilge pump. The AS888 automatic switch has a time-proven micro switch without mercury. When water exceeds the acceptable level, the pump is turned on by a rolling steel ball, which changes the pressure on the micro switch. The AS888 attaches to any Johnson Pump bilge pump through the clip on "T-slot" and can be used with 6, 12, 24 or 32 V systems. Use AS888 for a better and safer life afloat!

Order No. Max Amp.  
 34-888 15A



Model No.	Description
34-72303-001	Bilge Alert, High Water Alarm 12 V
34-72303-002	Bilge Alert, High Water Alarm 24 V

## Ultima Switch™

New digital technology uses the patented Mirus field effect detector cells producing micro-electrical fields that detect disruptions caused by water and fluids. Detector cells are totally sealed are never in contact with the water, will not corrode and are not affected by oil or foreign debris. No moving parts, totally sealed solid state electronics and field detectors, no mercury and no exposed sensors eliminate corrosion possibilities and makes the ULTIMA switch environmentally sensitive. ULTIMA activates at a 50 mm (2") fluid level and deactivates at a 20 mm (3/4") fluid level. A 3 second delay prevents false starts. ULTIMA switch is rated to handle pumps up to 20amps at 12 or 24 volts.

Model No.	Description
34-36303	ULTIMA Switch 20 Amp Max 12/24 V



## Johnson Pump Bilge Mate

A low budget alternative designed for long life and high performance capacity. The low cost choice for boat owners who still look for quality.

Capacity, straight: 30 L/min  
Voltage: 12 V DC  
Amperage: 2 A  
Fuse size: 3 A  
Hose size: 3/4"  
Max dia: 115 mm  
Max height: 100 mm  
Weight: 0.35 kg

Order No.  
32-1015-01



## Spare motor for cartridge

Upgrade the output of your bilge pump in a matter of a few minutes by replacing the cartridge. Cleaning debris from the impeller has never been simpler or easier.

Order No.  
32-1450C Motor for L450, L450 Duo  
32-1550C Motor for L550, L550 Duo  
32-1650C Motor for L650, L650 Duo  
32-1750C Motor for L750, L750 Duo



Lift a tab at the top, give the cartridge a twist, and pull the all-in-one motor/impeller unit out of the Cartridge.

## Bilge Pump Control – 12 or 24 V

Johnson Pump switch panel gives full control of your equipment. Just push the button for manual or automatic bilge pumping. The automatic feature operates in combination with the automatic bilge switches or the electronic float switch from Johnson Pump. The three-position switch panel in matt black finish has an integrated fuse holder and operating light. Fuses included.

Size: 73x60 mm, 40 mm depth.

Order No.  
34-1224 12 V  
34-1225 24 V



## Side Mount Bracket

Gives opportunity to mount the pump on a wall. Suitable for Cartridge and Cartridge Duo.

Order No.  
34-900



# LIVEWELL AERATING PUMPS

## Twin Port Pumps

New twin outlet port pumps offer the convenience of using only one intake for both the live well and raw water wash down pump. The 3/4" tapered inlet connects directly to the sea cock and the upper outlet port provides a continuous flow of water through the 3/4" discharge to the live well while the lower outlet port connects to the wash down pump through either a 1/2" or 3/4" ports. New high pressure inlet seal easily handles the higher pressures created by high speed pickups commonly used.



Order No.	Description
32-48503	550 GPH Twin Port LiveWell/Aerator Pump
32-48703	750 GPH Twin Port LiveWell/Aerator Pump

## Cartridge Aerator Pump

Livewell pumps in 500 GPH and 750 GPH capacities with two different intake configurations of straight and 90°. Smaller profiles to fit in more confined spaces. Easy to change motor cartridge. Johnson Pump cartridge aerator pumps offer the ease of convenience and years of reliable service.



Order No.	Description
32-2850	500 GPH Cartridge aeratorpump straight
32-3850	500 GPH Cartridge aeratorpump 90°
32-2870	750 GPH Cartridge aeratorpump straight
32-3870	750 GPH Cartridge aeratorpump 90°

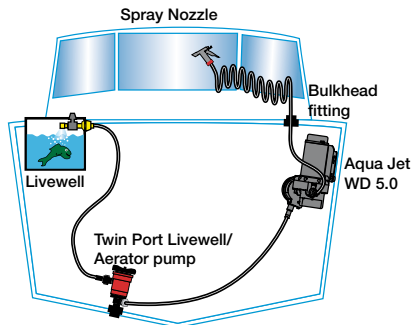

## Aqua Jet Wash Down / Livewell Pump Kit 5.2

A new wash down kit including a high capacity Aqua Jet WD 5.2, 5 bar (70 psi) pump, a 550 GPH Twin Port live well pump, PUMProtector inlet strainer, spray nozzle, bulk head fitting with valve, 7.5 meters (25') of coiled wash down hose and two illuminated panel switches all in one package. Aqua Jets wash down/live well pump kit makes it easy to add a wash down and live well pump to any boat.



Order No	Description
32-64634	Aqua Jet 5.2 WD/ 550 Live Well Pump Kit 12 V

## Ice Chest Aerator kit

Ice Chest Aerator converts any good sized ice chest (Esky) into your own portable live bait tank. The Ice Chest Aerator will keep your live bait alive, or catch fresh, even during the heat of the day. Includes a sturdy Bilge Mate pump, hose, spray bar, press on clamp, battery clamps and clear-cut instructions.



Since there are no holes to drill the chest can always be returned to its original purpose.

Order No.	Description
32-24052	Ice Chest Aerator kit

## In-well Aerator kit

In-well Aerator Kit is about the easiest way to add oxygen to your live bait well. Use it as your primary aerator, or to recirculate while you're making a long run across the bay, or if you are trailing the boat, you can stop for fuel and be aerating your catch while the boat is on the trailer.



A dependable 500 GPH forces water through the aerating head to provide vital oxygen for respiration ensuring your bait stays fresh longer. To empty the well at the end of the day, merely open the valve, activate the pump and water passes through a discharge fitting.

Order No.	Description
32-24014	In-well Aerator kit

# BILGE, DECKWASH AND REFUELLING



CE marked according to following standards:

## F2P10-19, F3B-19, F4B-19, F4B-11

- EN50082-1: 1992/Generic EMS Standard
- EN55014: 1993/Radio disturbance
- IEC801-2: 1984/Electrostatic Discharge
- IEC801-3: 1984/Radiated Immunity Test
- ISO8846: Small Craft – Electrical devices – Protection against ignition of surrounding flammable gases
- ISO8849: Small Craft – Electrically operated bilge pumps
- ISO10133: Small Craft – Electrical systems – Extra-low voltage d.c. installations

## F5B-19 12/24 V

- EN55014: 1993/Radio disturbance

With their high level of flexibility, these pumps are ideally suited for use in boats as bilge and deckwash pumps, fresh water pumps, refuelling pumps for oil and diesel. These pumps may be combined with a vacuum switch for automatic operation. Capacities vary from max 14 L/min to 55 L/min, allowing the proper matching of the pump to the application. All motors are heavy duty to provide long service life even under heavy use. Available in 12 or 24 volts.

### Oil Change

These DC driven flexible impeller pumps are deally suited for drain and refueling of both engine oil and diesel.

### Deckwash Pumping

DC driven flexible impeller pumps for deckwash. Heavy duty electrical self-priming deckwash pumps with long life motor which can run continuously under certain conditions. Flexible impeller pumps must not be run dry.

### Bilge Pumping

Bilge pumps with excellent suction and pressure ability. Solid particles and debris can be handle without damaging the pump. Should be installed in a dry, well ventilated position above, but as close to the liquid as possible. As the pumps must not be run dry, it is recommended to combine it with Johnson Pump vacuum switch that cuts off the current to the pump when the bilge is dry. For automatic/manual bilge pumping the pump can be combined with Johnson Pump bilge control panel and automatic switch. **Must not be run dry.**

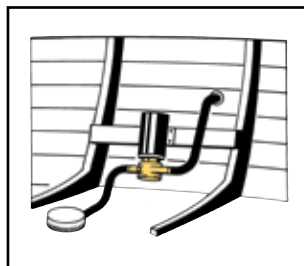
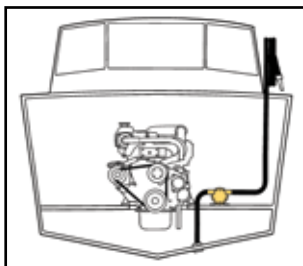

## DC driven Flexible Impeller pump

### Pressure and Capacity Data

(based on water at 20°C/68°F)

F2P10-19					Ampere draw	
Bar	kPa	ft	l/min	USGPM	12V	24V
0.15	15	5.0	14.0	3.7	7.2	3.5
0.3	30	10.1	13.5	3.6	7.4	3.6
0.6	60	20.1	10.5	2.8	7.9	3.8
0.75	75	25.1	9.0	2.4	8.3	4.0
0.9	90	30.2	7.0	1.9	8.7	4.2
Fuse required					16.0 A	8.0 A

F3B-19					Ampere draw	
Bar	kPa	ft	l/min	USGPM	12V	24V
0.15	15	5.0	15.3	4.0	7.1	3.5
0.3	30	10.1	14.0	3.7	7.4	3.6
0.6	60	20.1	10.9	2.9	7.9	3.8
0.9	90	30.2	7.3	1.9	8.5	4.0
1.2	120	40.2	2.7	0.7	9.5	4.2
Fuse required					15.0 A	8.0 A

F3B-19					Ampere draw	
Bar	kPa	ft	l/min	USGPM	12V	24V
0.15	15	5.0	33.1	8.8	10.8	5.0
0.3	30	10.1	31.2	8.2	11.0	5.1
0.6	60	20.1	25.4	6.7	11.9	5.3
0.9	90	30.2	15.3	4.0	13.8	6.2
1.2	120	40.2	1.3	0.3	15.8	6.5
Fuse required					25.0 A	15.0 A
Recommended wire size					4 mm <sup>2</sup>	25 mm <sup>2</sup>

F4B-19					Ampere draw	
Bar	kPa	ft	l/min	USGPM	12V	24V
0.15	15	5.0	46.0	12.2	14.2	7.2
0.3	30	10.1	42.3	11.2	15.0	7.6
0.6	60	20.1	34.8	9.2	16.5	8.4
0.9	90	30.2	23.9	6.3	18.3	9.3
1.2	120	40.2	11.2	3.0	19.6	9.9
Fuse required					25.0 A	15.0 A
Recommended wire size					4 mm <sup>2</sup>	25 mm <sup>2</sup>

F5B-19					Ampere draw	
Bar	kPa	ft	l/min	USGPM	12V	24V
0	0	0	55.0	14.5	23.2	11.9
0.3	30	10.1	49.4	13.1	24.2	12.8
0.6	60	20.1	39.9	10.5	25.1	13.3
0.9	90	30.2	30.1	8.0	26.2	14.0
1.2	120	40.2	19.3	5.1	28.0	14.7
1.5	150	50.3	9.3	2.4	29.8	15.3
Fuse required					50.0 A	25.0 A
Recommended wire size					16 mm <sup>2</sup>	6 mm <sup>2</sup>

**New!**



## DC driven Flexible Impeller pump

F2P10-19 is a fully equipped, self-priming multipurpose pump operating on a simple and uncomplicated principle. Ideal for pumping water, oils and chemicals.

F3B-19, F38B-19, F4B-19 are perfect for bilge pumping, deckwash, water circulation, oil and diesel refuelling at dockside service, etc.

F5B-19 is for bilge pumping, deckwash, water circulation, oil and diesel refuelling at dockside service, etc.

The motor can be run continuously up to 0.5 bar \*) and for max 1 hour at 1 bar \*).

Vacuum switch as extra accessory for F3B-19, F4B-19 and F5B-19, see below.

*NOTE! Do not use any of the pumps mentioned above for pumping paraffin or other thin petroleum products*

\*) At nominal voltage and room temperature.

Pump	Part no	Motor	Body	Impeller	Seal	Connection	Lenght (mm)	Width (mm)	Height (mm)	Weight (kg)
F2P10-19	10-24180-1	12V	PTMT	09-1077B-9	Lip seal	1/2" hose	172	117	78	1,6
F2P10-19	10-24180-2	24V	PTMT	09-1077B-9	Lip seal	1/2" hose	172	117	78	1,6
F3B-19	10-24516-01	12V	Bronze	09-1052S-9	Lip seal	3/8" BSP	170	100	82	2
F3B-19	10-24516-02	24V	Bronze	09-1052S-9	Lip seal	3/8" BSP	170	100	82	2
F38B-19	10-24727-01	12V	Bronze	09-824P-9	Lip seal	Hose 1" / 1/2" BSP	180	120	90	3
F38B-19	10-24727-02	24V	Bronze	09-824P-9	Lip seal	Hose 1" / 1/2" BSP	180	120	90	3
F4B-19	10-24689-01	12V	Bronze	09-824P-9	Lip seal	Hose 1" / 1/2" BSP	202	120	90	3
F4B-19	10-24689-02	24V	Bronze	09-824P-9	Lip seal	Hose 1" / 1/2" BSP	202	120	90	3
F4B-11 Ultra Ballast	10-24690-01	12V	Bronze	09-824P-1	Lip seal	Hose 1" / 1/2" BSP	202	120	90	3
F4B-11 Ultra Ballast	10-24690-02	24V	Bronze	09-824P-1	Lip seal	Hose 1" / 1/2" BSP	202	120	90	3
F5B-19	10-24188-1	12V	Bronze	09-1027B-9	Mech. seal	3/4" BSP	258	131	120	8
F5B-19	10-24188-2	24V	Bronze	09-1027B-9	Mech. seal	3/4" BSP	258	131	120	8

## Ultra Ballast pump

Designed to quickly fill or when reversed, drain a ballast tank at a rate of more than 45 L/min (12 GPM). Capable of pumping fresh or sea water the pump's robust design can handle the rigors of continues duty usage, is reversible, and has a built in thermal overload for added protection. Care not to run dry for extended periods of time will increase the pump longevity and ensure reliable performance for many years.

*Note! Only for waterhandling. For technical information see table above.*



Order No.

10-24690-01 12 V

10-24690-02 24 V

## F3P10 Mini pump

Portable selfpriming pump suitable for chemicals, oils, diesel fuel and water. Selfpriming up to 2 m. 17 litre/minute at 2800 RPM. 1/2" hose connections. Fits any standard drilling-machine.

Do not run dry for more than 10 seconds.

Do not use for gasoline or other highly flammable liquids.



Order No.

10-32579-1

## Vacuum Switch

for automatic shut off operation and to prevent pump damage. The switch works with all selfpriming impeller pumps and should be used for e.g. bilge pumping/emptying of tanks to prevent the pump from dry running. The switch automatically shuts the pump off when the bilge/tank is dry. With the switch fitted, you can start the pump by remote push button or manually by depressing lever on the switch.



Order No. 09-45053

## Polarity Reversing Switch Kit

For Ultra Ballast pump F4B-11

Order No.

09-47196



## Deckwash Kit for F4B-19

For convenient deckwash. Includes

- Pressure switch
- Check valve
- Trigger nozzle

Order No.

09-46553



# BILGE, WASTE AND TOILET HANDLING



CE marked according to following standards:

**Recreational Craft Directive 94/25/EEC**

ISO8846: Small Craft – Electrical devices – Protection against ignition of surrounding flammable gases

ISO10133: Small Craft – Electrical systems – Extra-low voltage d.c. installations

ISO8849: Small Craft – Electrically operated bilge pumps

**Electromagnetic Compatibility Directive 89/336/EEC**

EN55014: 1993/Radio disturbance



Viking Power Vacuum

Crank for manual handling

Viking Power 32

## Viking Power 32 & Viking Power Vacuum – Compact toilet handling and waste water pump

The Viking Power 32 and Viking Power Vacuum diaphragm pumps have been designed to meet the rigorous demands of the world's leading manufacturers of boats, recreational vehicles and busses. Thanks to its single-chamber design and non-choke valves, the Viking Power 32, can be used to pump un-macerated sewage to a holding tank or transfer it onwards to a septic tank. The Viking Power Vacuum has double check-valves and can therefore also be used in vacuum toilet systems. Naturally, pumping ordinary shower or sink drain water or bilge water is no problem for either pump. Like the Viking Power 16, this new pump has been engineered with a ball-bearing supported transmission for long service life. The pump can not only be run dry, it can also handle a mixture of air and water without difficulty. The Viking Power 32/Vacuum provides maximum flow of 32 liters per minute and is self-priming up to a height of 2.5 (32) or 5 (Vacuum) meters. Although powered by an electric motor, this pump can also be cranked by hand in an emergency. The pump has been designed to prevent the leakage of unpleasant odors; and the Viking Power 32/Vacuum can be installed in a variety of different positions. The Viking Power 32/Vacuum is built to last, yet priced competitively.

## Viking Power 32 & Viking Power Vacuum Features

- Maximum flow 32 l/min
- Specifically engineered to pump black wastewater
- Uncompromising odor-prevention features
- Whisper quiet operation
- Self-priming
- High-impact glass-fiber reinforced nylon body
- Ball-bearing supported transmission
- Non-choke valves – no waste shredding required
- Pump head rotatable 360°
- Double check valves on Viking Power Vacuum
- Self-priming up to 2.5 meters (8.2 feet)
- Can be run dry and can pump air/water mixture
- Robust single diaphragm
- Electric motor with power-out, manual-crank backup
- Complies with ISO 15083 and small craft bilge pump standard for vessels above 12 m (39.4 ft)

**Technical specifications:**

<b>Capacity:</b>	32 l/min (8.5 GPM) open flow 30 l/min (7.9 GPM) at 0.1 bar
<b>Max head:</b>	4 m (13.1 ft)
<b>Max lift:</b>	VP32: 2.5 m (8.2 ft) VP Vacuum: 5 m (11.5 ft)
<b>Dimensions</b>	
<b>VP32:</b>	277 mm long x 264 mm wide x 192 mm high
<b>VP Vacuum:</b>	357 mm long x 271 mm wide x 192 mm high
<b>Ports:</b>	38 mm diameter (1½")
<b>Weight:</b>	VP32: 5.0 kg (11.0 lbs) VP Vacuum: 5.1 kg (11.2 lbs)
<b>Motor:</b>	3.5 amp (12V), 1.8 amp (24V) at 0.1 bar 12/24V DC (with built-in thermal protection)
<b>Body:</b>	Nylon
<b>Valves:</b>	Nitrile rubber
<b>Diaphragm:</b>	Reinforced nitrile rubber

**Order no.**

10-13373-03	Viking Power 32 12 V
10-13373-04	Viking Power 32 24 V
10-13373-07	Viking Power Vacuum 12 V
10-13373-08	Viking Power Vacuum 24 V

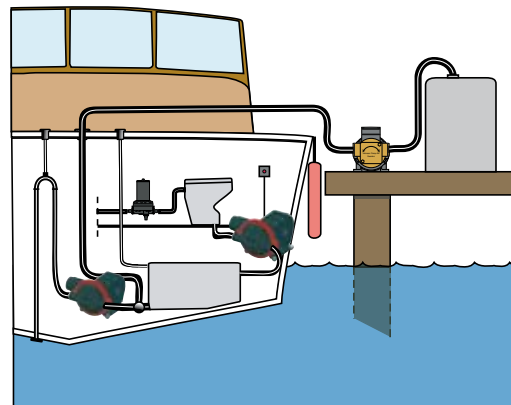



## Viking Power 16

### Features

- Specifically designed to pump wastewater
- Easy to install, even in tight spaces
- Quiet operation
- High-impact glass-fiber reinforced nylon body
- Ball-bearing supported transmission
- Non-choke valves – no filters required
- Self-priming up to 3 meters (9.8 feet)
- Can be run dry and can pump air/water mixture
- Robust single diaphragm
- KlickTite™ XL connectors standard
- 12V or 24V motors
- Low power consumption
- Complies with ISO 15083 and small craft bilge pump standard for vessels up to 12 m (39.4 ft).



Perfect for installation in tight spaces, the Viking Power 16 shower drain pump can be incorporated into a small boat wastewater system in several different pump/motor configurations. Compact, robust and adaptable, this pump can be mounted virtually anywhere on board. The Viking Power 16 has KlickTite™ XL connectors fitted as standard, literally making hose connections a snap!

## Grey Water Tank

The Grey water tank is designed to be used as collection tank for waste water from showers, sinks, dishwashing machines, etc with 19 mm, 25 mm and 38 mm inlet ports, and 19 mm and 25 mm outlet ports. The tank includes an Ultima Switch for automatic operation and is easy to connect to any 12V/24V pump up to 20 amp. The tank is prepared for Viking Power 16, with pre-drilled holes for the pump.

Dimensions: 185x280x340 mm

Order no: 09-13384  
Grey Water Tank  
excl. Viking Power 16



## Viking Power 16 — Compact shower drain, bilge and waste water pump

An ultramodern, single-chamber, self-priming diaphragm pump that can be set up in several different pump/motor configurations. It is easy to install anywhere after the drain outlet in the wastewater system or as a bilge pump in any leisure craft -- new or used.

Its non-choke valves mean that no in-line filters are necessary, and the pump can not only be run dry, it can also handle a mixture of air and water without difficulty. The Viking Power 16 is self-priming up to a height of 3 meters.

With its low pulse and muffled rubber bracket, this pump offers quite operation. Specifically designed to pump wastewater, the Viking Power 16 has been built to last, and engineered for easy maintenance. When it comes time to replace the premium grade reinforced nitrile rubber diaphragm, you can put in a spare without even removing the pump from the system. Delivered with 1" hose and ¾" hose ½" BSP KlickTite™ XL connectors. 90° KlickTite™ XL connectors available as extra accessory.

### Technical specifications:

<b>Capacity:</b>	16 l/min (4.2 GPM) open flow (15 l/min at 0.1 bar)
<b>Max. head:</b>	3 meters (9.8 feet)
<b>Max. lift:</b>	3 meters (9.8 feet)
<b>Dimensions:</b>	186 mm long x 235/181 mm wide x 118/204 mm high
<b>Connection:</b>	KlickTite™ XL connectors for 1" hose or ¾" hose and ½" BSP threads; straight and 90° (optional)
<b>Weight:</b>	2.6 kg (5.7 pounds)
<b>Motor:</b>	2.3 amp (12V), 1.2 amp (24V) at 0.1 bar 12/24V DC (with built-in thermal protection)
<b>Body:</b>	Nylon, glass-fiber reinforced
<b>Valves:</b>	Nitrile rubber
<b>Diaphragm:</b>	Reinforced nitrile rubber

### Order No.

10-13350-03	Viking Power 16 12 V
10-13350-04	Viking Power 16 24 V

### Spareparts

09-47116	Straight ¾" hose
09-47117	Straight 1" hose
09-47118	90° ¾" hose
09-47119	90° 1" hose

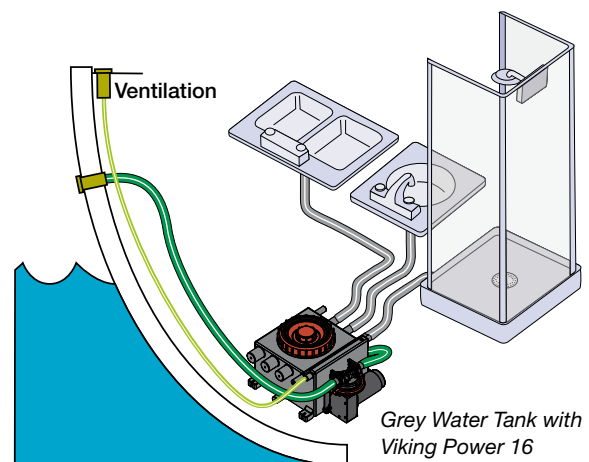

## Macerator Pump



CE marked according to following standards:

### Recreational Craft Directive 94/25/EEC

ISO8846: Small Craft – Electrical devices – Protection against ignition of surrounding flammable gases

ISO10133: Small Craft – Electrical systems – Extra-low voltage d.c. installations

### Electromagnetic Compatibility Directive 89/336/EEC

EN55014: 1993/Radio disturbance

The Johnson Pump macerator pump, TA3P10-19, takes care of toilet waste. A rotary cutter shreds waste before it is pumped into or out from the holding tank. The pump should be connected as close as possible to the holding tank discharge outlet or the bowl discharge outlet. *Note! Use unbleached lavatory paper only.* Do not run pump dry, however the motor has built-in thermal protection reducing the risk of damage when the pump is run dry.

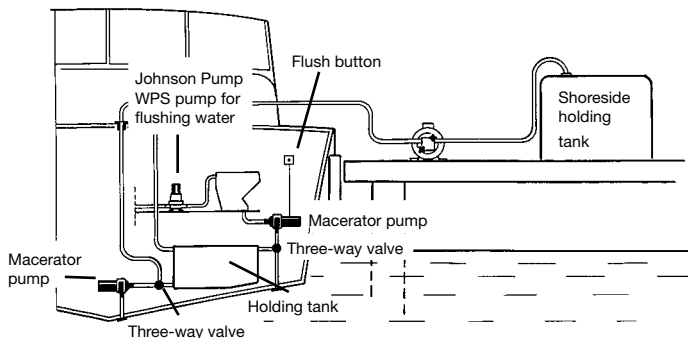

## TA3P10-19 – 12/24 V

<b>Pump body:</b>	Phenol plastic (PF)
<b>Impeller:</b>	09-1052S-9 (nitrile)
<b>Housing:</b>	Thermoplastic polyester (PET)
<b>Shaft:</b>	Stainless steel
<b>Seal:</b>	Lip seal
<b>Hose connection:</b>	Inlet 1.1/2" (dia 38 mm) hose or 1.1/2" BSP Outlet 25.4 mm (1") hose
<b>Motor:</b>	12 or 24 V DC (with built-in thermal protection)
<b>Capacity:</b>	37L/min at 0.2 bar (10 GMP at 6.7 ft)

### Dimensions and Weight

<b>Length:</b>	230 mm
<b>Width:</b>	108 mm
<b>Height:</b>	82 mm
<b>Weight:</b>	1.9 kg

### Order No.

10-24453-04	12 V
10-24453-05	24 V



## Viking Thrudeck and Bulkhead

When the power is out you can always depend on the hand operated diaphragm bilge pump from Johnson Pump. The Viking pump can also be used for pumping toilet waste due to the large valve openings. The pump is available in two models for various installation alternatives. It can be mounted behind walls, through deck and under bulkheads.

Viking Thrudeck for installation behind vertical wall or under deck with sealing boot, complete with a cover plate. Viking Bulkhead for surface installation with horizontal lever.

<b>Pump Body:</b>	PP
<b>Shaft:</b>	Stainless steel AISI 316
<b>Screws:</b>	Stainless steel AISI 316
<b>Elastomers:</b>	Nitrile
<b>Handle:</b>	Anodised aluminium
<b>Connection:</b>	1.1/2" or 1" hose

### Dimensions and Weight

<b>Diameter:</b>	164 mm
<b>Handle length:</b>	285 mm
<b>Width:</b>	253 mm
<b>Height:</b>	133 mm
<b>Weight:</b>	2 kg

### Capacity Data

(At 1 m suction height : 0.9 L/stroke)

<b>Capacity at:</b>	
60 stroke/min	54 L/min
80 stroke/min	72 L/min
100 stroke/min	90 L/min

### Max suction height 4 m

<b>Order No.</b>	<b>Description</b>
70-50005	Thrudeck 1.1/2"
70-50025	Thrudeck 1"
70-50007	Bulkhead 1.1/2"
70-50027	Bulkhead 1"



# CIRCULATION PUMPS



CE marked according to following standards:

## CM10P7-1, CM30P7-1, CM90

EN55014: 1993/Radio disturbance  
 ISO8846: Small Craft – Electrical devices – Protection against ignition of surrounding flammable gases  
 ISO10133: Small Craft – Electrical systems - Extra-low voltage d.c. installations  
 72/245/EEG, 95/54/EG Electromagnetic compatibility

## C090P5-1

EN55014: 1993/Radio disturbance  
 72/245/EEG, 95/54/EG Electromagnetic compatibility

A line of compact magnetic driven centrifugal pumps, CM10 and CM30 and the new as top of the line; CM90, which combine high flow rates with very low electric current consumption, making them ideally suited for circulating fresh water in live fish tanks, heating and cooling systems. C090 with mechanical seal and a motor is designed for continuous operation. Designed for also handling fresh water handling.

## Heavy Duty Magnetic Driven Centrifugal Pump & Heavy Duty Centrifugal Pump

### CM10 & CM30

Pump body: PPA thermoplastic  
 Impeller: PPS thermoplastic  
 O-ring: EPDM  
 Shaft: Stainless steel  
 Magnet housing: PSU  
 Motor: 12/24 V DC enclosed (as per IP67) permanent magnet, ball bearing mounted motor, designed for continuous operation

Liquid temp.: Min -40°C Max +100°C  
 Hose connection: Ø 16 mm (5/8") or 20 mm (3/4") hose.  
 Note! CM30P7-1 only available with 20 mm hose connection.

#### Dimensions and Weight

	CM10P7-1	CM30P7-1
Length:	177 mm	177 mm
Width:	68 mm	68 mm
Height:	85 mm	85 mm
Weight:	0.53 kg	0.6 kg



#### Order No.

Ø 16 mm  
 10-24501-03 CM10P7-1 12 V, 15L/min at 0.1 bar (4GPM at 3.3 ft)  
 10-24501-04 CM10P7-1 24 V, 15L/min at 0.1 bar (4GPM at 3.3 ft)  
 Ø 20 mm  
 10-24502-03 CM10P7-1 12 V, 18.5L/min at 0.1 bar (5GPM at 3.3 ft)  
 10-24502-04 CM10P7-1 24 V, 18.5L/min at 0.1 bar (5GPM at 3.3 ft)  
 10-24504-03 CM30P7-1 12 V, 26L/min at 0.1 bar (6.9GPM at 3.3 ft)  
 10-24504-04 CM30P7-1 24 V, 26L/min at 0.1 bar (6.9GPM at 3.3 ft)

### CM90

Capacity: 90 liters/min (23.7 GPM) at 0.25 bar  
 System pressure: -0.3 to +3.0 bar; stationary max. 4.0 bar  
 Liquid: water/glycol mixture; max. 60% glycol  
 Motor service life: More than 5,000 hours at nominal voltage 10,000 start/stops. Interchangeable motor.  
 Motor, voltage: Nominal 13.6V DC for use between 10-16V  
 Nominal 27.2V DC for use between 20-32V  
 Input power: Max. 125W  
 Dry running: 30 minutes  
 Dimensions: 244 mm long x 120 mm wide x 150 mm high  
 Ports: Ø 38 mm (1 1/2")  
 Weight: 3.0 kg (6.6 pounds)  
 Body: PPA, glass-fiber reinforced  
 Mounting: Separate universal bracket for flat surfaces

#### Order no.

10-24664-01 CM90 12 V  
 10-24664-02 CM90 24 V



### C090

Pump body: PA66 thermoplastic  
 Impeller: PA66 thermoplastic  
 Shaft: Stainless steel  
 Shaft seal: Mechanical seal  
 Motor: 12/24 V DC enclosed (as per IP31) permanent magnet, ball bearing mounted motor, designed for continuous operation

Liquid temp.: Min -30°C Max +100°C  
 Hose connection: Ø 38 mm (1.1/2") hose

#### Dimensions and Weight

Length: 211 mm  
 Width: 117 mm  
 Height: 110 mm from baseplate (totally 116 mm)  
 Weight: 1.75 kg



#### Order No.

10-24190-1 12 V, 100L/min at 0.1 bar (26.4GPM at 3.4 ft)  
 10-24190-2 24 V, 100L/min at 0.1 bar (26.4GPM at 3.4 ft)

# TOILETS, MANUAL AND ELECTRIC

## AquaT™ Marine toilets

**New!**

### Manual or electric powered

Available in a wide variety of different versions marketed under three basic models — standard and premium electric-powered or manual — the Johnson Pump AquaT™ marine toilet has been designed to meet virtually every conceivable lavatory installation situation onboard.

Priced competitively, the fine finish and well thought-through design of these toilets is remarkable. Made from white vitreous porcelain, and with corrosion resistant parts throughout, the Johnson Pump AquaT™ marine toilet, is quiet, robust and easy to clean. Using the Johnson Pump AquaT™ marine toilet, water inlet and outlet takes place in two distinct steps. First the bowl is filled with clear water, and then the waste is flushed, leaving the bowl empty and clean, with no liquids sloshing about. Naturally, automatic back-flow prevention is incorporated into the design.

Most models can be ordered with standard, bevelled or low profiles in order to fit almost any hull and bulkhead configuration, and all are available in either compact or comfort versions so you can outfit your marine lavatory with the perfect-sized toilet, no matter what the layout.

The AquaT™ toilet will give you years of trouble free operation. When spare parts such as a new seat or valve are needed, you'll find Johnson Pump's global network of distributors at your service.

Power models are shipped with well-proven Aqua Jet diaphragm pumps in either 12V or 24V versions, and the manual version incorporates an ergonomically designed, hand-powered piston pump that can be mounted for either left-hand or right-hand use.

It's probably fair to think of most toilets as commonplace products, but look at the features and you're sure to see that the AquaT™ is far from ordinary. Quiet, hygienic and reliable, the Johnson Pump AquaT™ marine toilet is perfect for almost any marine toilet room.

### Technical specifications:

Toilet bowl:	100% vitreous china
Toilet Seat:	Wood with baked enamel finish
Water consumption:	2-2.5 liters per flush
Dimensions:	See page 22
Outlet ports:	Ø 38mm (1½") & 25 mm (1")
Inlet ports:	Ø 19mm (¾")
Weight:	See previous page
Motor*:	13 amp (12V), or 7 amp (24V) Aqua Jet pump

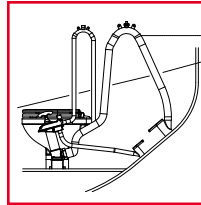

Toilet mounted below the waterline and discharging overboard.

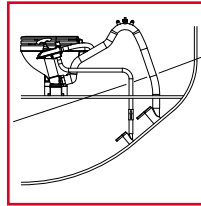

Toilet mounted above the waterline and discharging overboard.

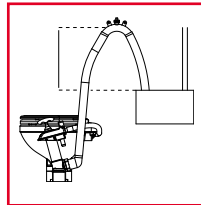

Toilet waste discharging into holding tank, discharging elbow always above top of the holding tank.

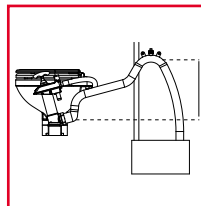

Toilet waste discharging into holding tank, discharging elbow below top of the holding tank at any time.

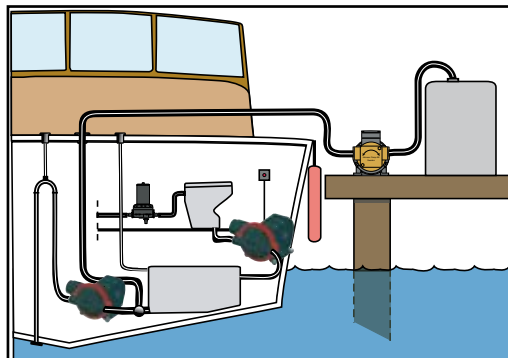

## Features

### All versions

- Whisper quiet operation
- Self-priming pump
- Clean lines – pleasing to the eye
- Hygienic, easy-to-clean vitreous china bowl and exterior surfaces
- Robust wooden seat with durable baked enamel finish
- Low water consumption (2-2.5 l/flush) makes the most of holding tank capacity
- Versatile plumbing connection options
- Automatic back-flow prevention
- Available in comfort or compact bowl sizes
- Designed for virtually any onboard mounting position
- May be installed above or below the waterline
- Suitable for OEM or replacement installation
- Corrosion resistant materials throughout
- Long service life

### The manual versions

- Ergonomic pump handle for ease of use
- Pump can be mounted left or right of the toilet bowl
- Innovative brake bushing prevents annoying leakage at the handle

## AquaT™ Manual

**New!**



80-47229-01 Compact



80-47230-01 Comfort

### The power versions

- Equipped with 12V or 24V Aqua Jet pumps
- Quick-connect hose or threaded connectors
- Complies with ISO 8846, ignition protection, and EN 55014 EMC

## AquaT™ Silent Electric



80-47231-01 Compact 12 V  
80-47231-02 Compact 24 V



80-47232-01 Comfort 12 V  
80-47232-02 Comfort 24 V

## AquaT™ Premium



80-47233-01 Low 12 V  
80-47233-02 Low 24 V



80-47234-01 Low, bevelled 12 V  
80-47234-02 Low, bevelled 24 V



80-47235-01 Std. 12 V  
80-47235-02 Std. 24 V



80-47236-01 Std. bevelled 12 V  
80-47236-02 Std. bevelled 24 V

### Order no.

#### AquaT™ Manual

80-47229-01 Compact, Manual  
80-47230-01 Comfort, Manual

#### AquaT™ Electric

80-47231-01 Compact 12 V  
80-47231-02 Compact 24 V  
80-47232-01 Comfort 12 V  
80-47232-02 Comfort 24 V

### Order no.

#### AquaT™ Premium, Low

80-47233-01 Low 12 V  
80-47233-02 Low 24 V  
80-47234-01 Low, bevelled 12 V  
80-47234-02 Low, bevelled 24 V

#### AquaT™ Premium, Std

80-47235-01 Std. 12 V  
80-47235-02 Std. 24 V  
80-47236-01 Std. bevelled 12 V  
80-47236-02 Std. bevelled 24 V

From a name you can trust, the Johnson Pump AquaT™ toilet provides the comfort and convenience of a land-based lavatory at sea — A marine toilet that flushes as quietly as a toilet on land

## Dimensions

### AquaT™ Manual Toilets

Model No	Description	Net Weight	A	B	C	D	E	F	
80-47229-01	Compact bowl	9,6 kg	345	650	215	425	450	170	mm
80-47230-01	Comfort bowl	11 kg	340	705	275	490	470	185	mm

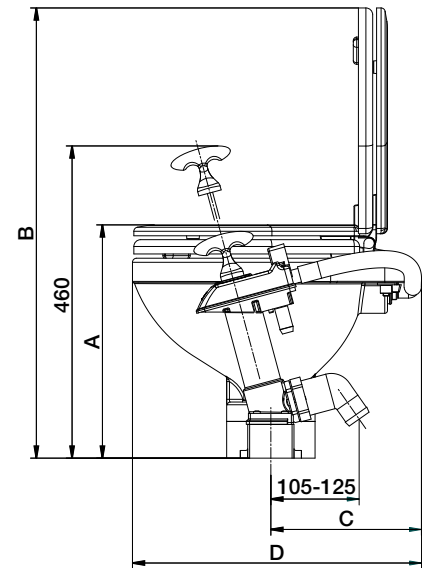
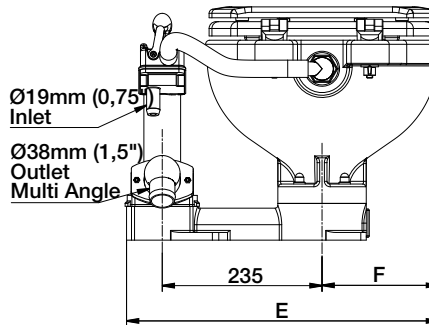
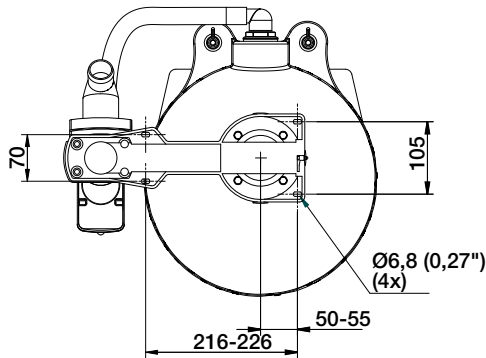

### AquaT™ Silent Electric Toilets

Model No	Description	Net Weight	A	B	C	D	E	F	G	
80-47231-01	Compact bowl	9,6 kg	120	390	335	420	215	290	700	mm
80-47231-02	Compact bowl	9,6 kg	120	390	335	420	215	290	700	mm
80-47232-01	Comfort bowl	11 kg	190	385	365	490	275	280	755	mm
80-47232-02	Comfort bowl	11 kg	190	385	365	490	275	280	755	mm

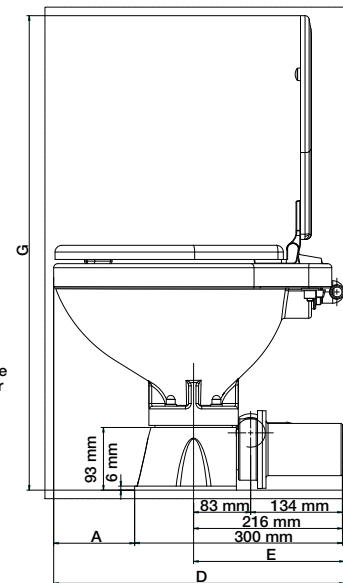
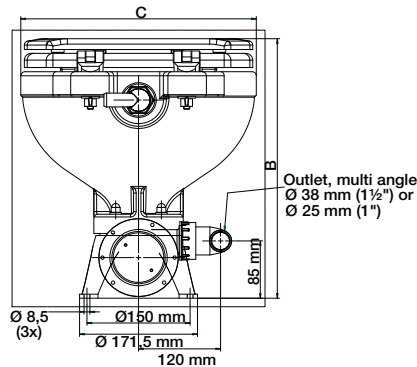

### AquaT™ Premium Silent Toilets, Low and Standard

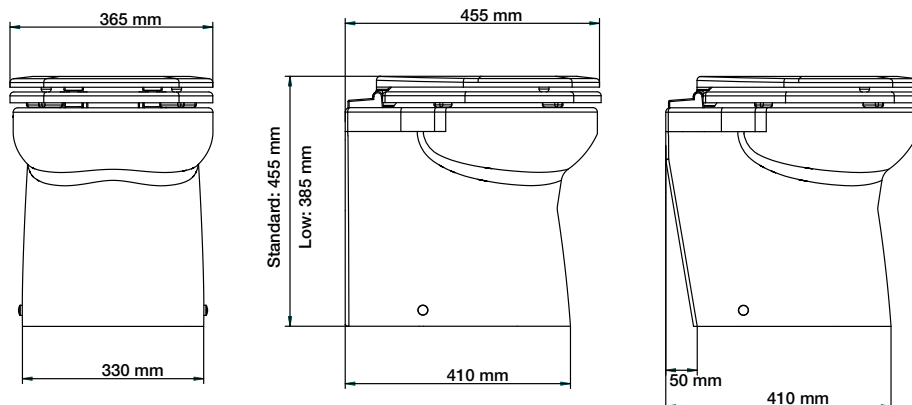

## Accessories

**New!**



### Control Panel

Order no.	Description
81-36105-01	12 & 24V



### Flush 2.9 Pump

Order no.	Description
10-24677-01	12V
10-24677-02	24V



### Vented loop

Order no.	Description
81-47237-01	3/4"
81-47237-02	1"
81-47237-03	1.1/2"



### Viking Power 32

Toilet handling and waste water disposal pump

Order no.	Description
10-13373-03	Viking Power 32 12 V
10-13373-04	Viking Power 32 24 V



### Y-valve

Order no.	Description
81-47238-01	



### Conversion kit

Order no.	Description
81-47240-01	Conversion kit 12V
81-47240-02	Conversion kit 24V

## Spare Parts

Order no	Description	Order no.	Description
81-47239-01	Manual pump assembly	81-47245-01	Bowl Compact
81-47241-01	Wooden Seat Compact	81-47245-02	Bowl Comfort
81-47241-02	Wooden Seat Comfort	81-47245-03	Bowl Low
81-47241-03	Wooden Seat Premium	81-47245-04	Bowl Low. Bev
81-47242-01	Gasket kit, all gaskets in the manual toilet	81-47245-05	Bowl Std.
81-47243-01	Plastic base, plastic base and tap with the ring for manual toilet	81-47245-06	Bowl Std. Bev
81-47244-01	Plastic handle kit, only the plastic handle for manual toilet	81-47246-01	Intake elbow, inlet pipe gasket and nut for manual and silent electric versions
		81-47246-02	Outlet elbow, outlet pipe gasket and plastic nut
		81-47246-03	Intake elbow, inlet pipe gasket and plastic nut for Premium versions
		81-47247-01	Base group (silent electric and premium versions)
		81-47248-01	Motor group (silent electric and premium versions)



# SELF-PRIMING FLEXIBLE IMPELLER PUMPS

For high capacity bilge and deckwash pumps, nothing beats an electro-magnetic clutch pump from Johnson Pump. Also suitable as an emergency pump for e.g. fire fighting.

## Automatically Controlled Pumps

With an electro-magnetic clutch you will have pumping power whenever needed, at a push of a button, without being at the pump. Combined with a vacuum switch from Johnson Pump (recommended for bilge pump application), the clutch will automatically disengage whenever the pump starts priming air, thereby preventing dry running and pump damage.

Automatically controlled pumps are available in sizes from 1" to 2.1/2" (20 L/min to 625 L/min), with clutches in 12 or 24 volts. Wearing parts are easily replaceable and service kits are available for all standard models. (See our Spare part list JP-1400/01.)

Vacuum Switch as extra accessory.

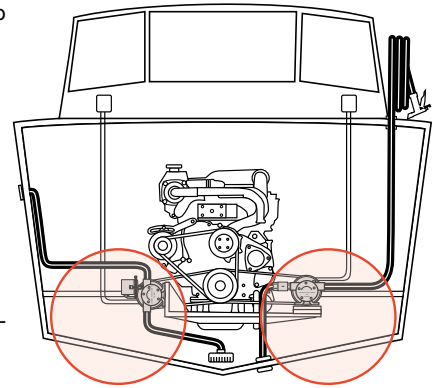

Bilge Pumping

Deckwash pumping

## Wiring Diagram

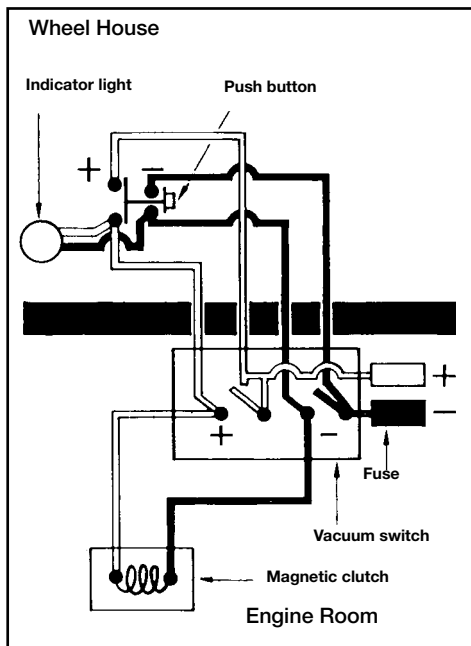

## Operating Principle

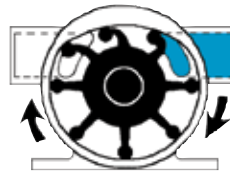

A vacuum is created as the flexible impeller vanes straighten upon leaving the cam, drawing liquid into the pump.



The rotating impeller carries liquid from the inlet to the outlet port. As a consequence of their design, flexible impeller pumps can pass fairly large solids.



When the flexible impeller vanes regain contact with the cam, they bend and the liquid is discharged from the pump in a uniform flow. Liquids can be pumped in the opposite direction by reversing the rotation of the pump.

## Vacuum Switch

for automatic shut off operation to prevent pump damage

The vacuum switch works with all self-priming impeller pumps and should be used for e.g. bilge pumping/emptying of tanks to prevent the pump from dry running. The vacuum switch automatically shuts the pump off when the bilge/tank is dry. With the switch fitted, you can start the pump by remote push button or manually by depressing lever on the switch.



Order No. 09-45053

# Clutch Pump

## Technical Specifications

Pump body: Bronze  
 Connection for vacuum switch  
 Shaft: Stainless steel  
 The shaft is mounted with permanently lubricated double ball bearings  
 Seal: Mechanical seal  
 Cam: Full or reduced  
 Connection: BSP, NPTF available on request  
 Clutch: Electro-magnetic 12/24 V DC  
 Pulley: 2xA or 1xB-groove  
 Pulley dia: ø178 mm

Performance see page 28,  
 Bronze Impeller Pump Performance Tables

## Choice of Clutch

Order No.  
 0.3454.001 electro-magnetic clutch, 12 V 2xA pulley  
 0.3454.002 electro-magnetic clutch, 24 V 2xA pulley  
 0.3454.003 electro-magnetic clutch, 12 V 1xB pulley  
 0.3454.004 electro-magnetic clutch, 24 V 1xB pulley

## Port adaptor kit

1.1/2" BSP (NPTF available on request)  
 Order No. 09-43112  
 2" BSP (NPTF available on request)  
 Order No. 09-46557-01

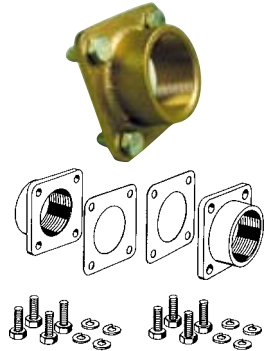

F7B-5001 F8B-5001

## Heavy Duty Electro-Magnetic Clutch Pump

Pump Model	Part No.	Impeller	Connection	Lenght (mm)	Width (mm)	Height (mm)	Weight (kg)
F7B-5001	10-24577-99	09-1028B	1" BSP	156	120	93	5,8
F8B-5001	10-13022-99	09-819B	1½" BSP	225	160	124	9,9



F7B-5000 F8B-5000 VF F8B-5000 TSS F9B-5600 F9B-5600 VF F9B-5600 TSS

## Extra Heavy Duty Electro-Magnetic Clutch Pump

Pump Model	Part No.	Impeller	Connection	Lenght (mm)	Width (mm)	Height (mm)	Weight (kg)
F7B-5000	10-24116-99	09-1028B	1" BSP	226	120	93	6,9
F8B-5000 VF	10-13025-99	09-819B	1½" BSP	265	152	154	11,9
F8B-5000 TSS	10-13176-99	09-819B	1½" BSP	265	198	151	11,9
F9B-5600	10-13027-99	09-814B	2" BSP	290	192	157	13,2
		09-802B					
F9B-5600 VF	10-13226-99	09-814B	2" BSP	290	152	175	13,2
		09-802B					
F9B-5600 TSS	10-13178-99	09-814B	2" BSP	290	200	151	13,2
		09-802B					



## Extra Heavy Duty, High Flow Electro-Magnetic Clutch Pump

Pump Model	Part No.	Impeller	Connection	Lenght (mm)	Width (mm)	Height (mm)	Weight (kg)
F95B-5600	10-13143-99	09-820B	2½" BSP	358	246/295	226/201	21

Flange with 2.1/2" BSP port adaptors (NPTF available on request)  
 The port adaptors can be fitted either vertically or horizontally

# SELF-PRIMING ALLROUND FLEXIBLE IMPELLER BRONZE PUMPS

## Heavy Duty Impeller Pump

A range of multipurpose bronze pumps. Compact design, raw water resistant pumps at an attractive price – with the renowned Johnson Pump quality. These pumps are designed for a number of applications on board.

With excellent self-priming capability, these pumps are ideal as cooling water pumps for marine engines, bilge pumps, deckwash pumps, fresh water pumps, fuel transfer pumps and other applications. Also ideally suited on shore to empty septic tanks, to flush clean and to fill water tanks. Available in sizes from 3/8" to 1.1/2" (4 L/min to 279 L/min).

Vacuum switch as extra accessory for F8B-8 only.

## Durable, Longer Life Flexible Impeller Pumps

### What makes a Johnson Pump better?

- Mechanical seal
- Double ball bearing
- Bearing spacer (double bearing life)
- Stainless steel endcover, wearplate and shaft
- O-ring sealed endcover
- Durable longer life
- Universal base and shaft dimensions



## Technical Specifications

Pump body: Bronze  
 Shaft: Stainless steel  
 The shaft is mounted with permanently lubricated double ball bearings  
 Seal: Mechanical seal  
 Cam: Full or reduced  
 Connection: NPTF available on request



Performance see page 28,  
 Bronze Impeller Pump Performance Tables

### Heavy Duty Impeller Pump

Pump Model	Part No.	Impeller	Connection	Lenght (mm)	Width (mm)	Height (mm)	Weight (kg)	Drive Shaft Ø
F35B-8	10-24569-01	09-808B-1	3/8" BSP	109	80	30	0,5	12k6
F4B-8	10-24570-01	09-810B-1 09-810B-9	3/8" BSP	111	80	50	0,5	12k6
F5B-8	10-24571-01	09-1027B-1 09-1027B-9	3/4" BSP	151	106	50	1,6	17k6
F7B-8	10-24572-01	09-1028B 09-1028B-9	1" BSP	170	120	50	1,9	17k6
F8B-8	10-13021-1	09-819B 09-819B-9	1.1/2" BSP	217	160	65	5,9	24h8



# Extra Heavy Duty Impeller Pump

Whenever you need greater strength or service from a pump, use a Johnson Pump extra heavy duty flexible impeller pump with separate bearing housing and mechanical seal for less wear and longer life.

These pumps cover the entire range of marine applications and may be used as cooling water pumps, bilge pumps, deckwash pumps, emergency and fire fighting pumps, etc. Available in sizes from 3/4" to 2.1/2" (13 L/min to 625 L/min). Wearing parts are easily replaceable and service kits are available for all standard models. (See our Spare part list JP-1400/01.)

Vacuum switch as extra accessory, see page 24.

## Technical Specifications

- Pump body:** Bronze. Connection for vacuum switch
- Shaft:** Stainless steel
- Seal:** Mechanical seal
- Cam:** Full or reduced
- Pedestal:** Cast iron with permanently lubricated double ball bearings
- Connection:** NPTF available on request



F5B-3000

F7B-3000

Performance see page 28,

Bronze Impeller Pump Performance Tables

### Extra Heavy Duty Impeller Pump

Pump Model	Part No.	Impeller	Connection	Length (mm)	Width (mm)	Height (mm)	Weight (kg)	Drive Shaft Ø
F5B-3000	10-24210-1	09-1027B-1 09-1027B-9	3/4" BSP	195	106	88	2,9	17
F7B-3000	10-24209-1	09-1028B 09-1028B-9	1" BSP	213	120	93	3,1	17
F8B-3000 VF	10-13024-1	09-819B 09-819B-9	1.1/2" BSP	255	152	154	7,6	24
F9B-3000	10-13026-1	09-802B 09-814B	2" BSP	282	192	157	9,3	24
F8B-3000 TSS	10-13175-01	09-819B 09-819B-9	1.1/2" BSP	255	198	151	7,6	24
F9B-3000 VF	10-13225-01	09-802B 09-814B	2" BSP	282	152	175	9,3	24
F9B-3000 TSS	10-13177-01	09-802B 09-814B	2" BSP	282	200	151	9,3	24

### Extra Heavy Duty, High Flow, Impeller Pump

F95B-3000	10-13121-01	09-820B	2.1/2" BSP	354	246/295	226/201	17,2	24
-----------	-------------	---------	------------	-----	---------	---------	------	----



F95B-3000



F8B-3000/F9B-3000



F9B-3000



F8B-3000/F9B-3000

## Port adaptor kit

1.1/2" BSP (NPTF available on request)  
Order No. 09-43112

2" BSP (NPTF available on request)  
Order No. 09-46557-01

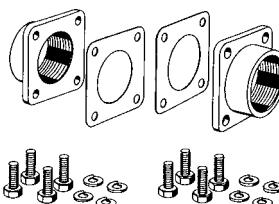

# Bronze Impeller Pump Performance Tables

Note!

Reduced cam - 30-40% lower capacity

Impeller of nitrile - adjust total head approx. 30% down

F35B			700 rpm			900 rpm			1400 rpm			1750 rpm			2000 rpm			2500 rpm		
Bar	kPa	ft	kW	l/min	USGPM	kW	l/min	USGPM	kW	l/min	USGPM	kW	l/min	USGPM	kW	l/min	USGPM	kW	l/min	USGPM
0.3	30	10.1	0.06	5.2	1.4	0.09	6.8	1.8	0.13	11.2	3.0	0.16	14.0	3.7	0.18	16.0	4.2	0.18	20.5	5.4
0.6	60	20.1	0.09	4.6	1.2	0.09	6.2	1.6	0.13	10.6	2.8	0.16	13.7	3.6	0.18	15.8	4.1	0.18	19.6	5.2
1.0	100	33.5	0.09	4.0	1.1	0.09	5.6	1.5	0.18	9.2	2.4	0.18	11.8	3.1	0.18	13.6	3.6	0.18	17.0	4.5

F4B			700 rpm			900 rpm			1400 rpm			1750 rpm			2000 rpm			2500 rpm		
Bar	kPa	ft	kW	l/min	USGPM	kW	l/min	USGPM	kW	l/min	USGPM	kW	l/min	USGPM	kW	l/min	USGPM	kW	l/min	USGPM
0.3	30	10.1	0.06	12.0	3.2	0.09	15.0	4.0	0.13	23.0	6.0	0.17	27.0	7.1	0.18	30.5	8.1	0.18	34.5	9.1
0.6	60	20.1	0.09	11.0	2.9	0.09	14.0	3.7	0.13	21.0	5.4	0.17	25.0	6.6	0.18	28.0	7.4	0.18	33.0	8.7
1.0	100	33.5	0.09	9.0	2.4	0.09	11.0	2.9	0.18	18.0	4.8	0.18	22.0	5.8	0.18	25.0	6.6	0.18	29.5	7.8
1.5	150	50.3	0.09	4.5	1.2	0.09	7.0	1.8	0.18	13.5	3.6	0.18	17.0	4.5	0.18	20.0	5.3	0.24	25.0	6.6

F5B			700 rpm			900 rpm			1400 rpm			1750 rpm			2000 rpm		
Bar	kPa	ft	kW	l/min	USGPM	kW	l/min	USGPM	kW	l/min	USGPM	kW	l/min	USGPM	kW	l/min	USGPM
0.3	30	10.1	0.13	16.0	4.2	0.18	21.0	5.5	0.37	33.0	8.7	0.37	41.0	10.8	0.37	46.0	12.2
0.6	60	20.1	0.13	15.0	4.0	0.18	20.0	5.3	0.37	32.0	8.5	0.37	39.5	10.4	0.37	45.0	11.9
1.0	100	33.5	0.13	14.0	3.7	0.18	19.0	5.0	0.37	30.0	7.9	0.37	37.0	9.8	0.37	42.0	11.1
1.5	150	50.3	0.13	13.0	3.4	0.18	17.0	4.5	0.37	27.0	7.1	0.37	33.5	8.9	0.37	38.0	10.0
2.0	200	67.1	-	-	-	-	-	-	0.37	22.0	5.8	0.37	28.5	7.5	0.37	33.0	8.07

F7B			700 rpm			900 rpm			1400 rpm			1750 rpm			2000 rpm		
Bar	kPa	ft	kW	l/min	USGPM	kW	l/min	USGPM	kW	l/min	USGPM	kW	l/min	USGPM	kW	l/min	USGPM
0.3	30	10.1	0.37	36.0	9.5	0.37	46.0	12.2	0.75	74.0	19.6	0.75	98.0	25.9	0.75	107.0	28.3
0.6	60	20.1	0.37	34.0	9.0	0.37	44.0	11.6	0.75	72.0	19.0	0.75	96.0	25.4	0.75	104.0	27.5
1.0	100	33.5	0.37	29.0	7.7	0.37	40.0	10.6	0.75	67.0	17.7	0.75	87.0	23.0	0.75	98.0	25.9
1.8	180	60.4	0.37	21.0	5.5	0.37	30.0	7.9	0.75	57.0	15.1	0.75	73.0	19.3	0.75	84.0	22.2
2.5	250	83.8	-	-	-	-	-	-	0.75	37.0	9.8	1.1	52.0	13.7	1.1	63.0	16.6

F8B			700 rpm			900 rpm			1400 rpm			1750 rpm			2000 rpm		
Bar	kPa	ft	kW	l/min	USGPM	kW	l/min	USGPM	kW	l/min	USGPM	kW	l/min	USGPM	kW	l/min	USGPM
0.3	30	10.1	0.37	87.0	9.5	0.75	114.0	30.1	1.1	188.0	50.0	1.5	241.0	63.7	1.5	279.0	73.7
0.6	60	20.1	0.37	80.0	9.0	0.75	107.0	28.3	1.1	180.0	47.6	1.5	233.0	61.6	1.5	270.0	71.3
1.0	100	33.5	0.37	73.0	7.7	0.75	101.0	26.7	1.1	177.0	46.8	1.5	228.0	60.2	1.5	264.0	69.7
1.8	180	60.4	-	-	-	1.1	70.0	18.5	1.1	148.0	39.1	2.2	203.0	53.6	2.2	242.0	63.4
2.5	250	83.8	-	-	-	-	-	-	1.1	108.0	28.5	2.2	166.0	43.9	2.2	208.0	55.0

F9B-5000			700 rpm			900 rpm			1400 rpm			1750 rpm			2000 rpm		
Bar	kPa	ft	kW	l/min	USGPM	kW	l/min	USGPM	kW	l/min	USGPM	kW	l/min	USGPM	kW	l/min	USGPM
0.3	30	10.1	0.75	129.0	34.1	0.75	170.0	44.9	1.5	268.0	70.8	1.5	331.0	87.5	2.2	388.8	102.7
0.6	60	20.1	0.75	124.0	32.8	0.75	161.0	42.5	1.5	260.0	68.9	2.2	323.0	85.3	2.2	383.1	101.2
1.0	100	33.5	0.75	118.8	31.4	1.1	156.0	41.2	1.5	255.6	67.5	2.2	315.2	83.3	3.0	379.2	100.2
1.8	180	60.4	1.1	105.0	27.7	1.1	140.0	37.0	1.5	235.0	62.1	2.2	286.1	75.6	3.0	351.3	92.8
2.5	250	83.8	1.1	83.7	22.1	1.5	102.0	26.9	2.2	208.0	55.2	3.0	266.0	70.3	3.0	304.1	80.3

F9B-5600			700 rpm			900 rpm			1400 rpm			1750 rpm			2000 rpm		
Bar	kPa	ft	kW	l/min	USGPM	kW	l/min	USGPM	kW	l/min	USGPM	kW	l/min	USGPM	kW	l/min	USGPM
0.3	30	10.1	0.75	129.0	34.1	1.1	170.0	44.9	1.5	270.0	71.3	1.5	331.0	87.5	2.2	376.0	99.3
0.6	60	20.1	0.75	126.0	32.8	1.1	165.0	43.6	1.5	266.0	70.3	2.2	323.0	85.3	2.2	368.0	97.2
1.0	100	33.5	0.75	123.0	32.5	1.1	161.1	42.6	2.2	260.0	68.7	2.2	314.0	83.3	3.0	361.0	95.4
1.8	180	60.4	0.75	110.0	29.1	1.5	153.0	40.4	2.2	242.0	63.9	2.2	291.0	76.9	3.0	340.0	89.8
2.5	250	83.8	1.1	90.0	23.8	1.5	130.0	34.3	2.2	218.0	57.6	3.0	269.0	71.1	3.0	312.0	82.4
3.0	300	100.6	1.5	61.0	16.1	2.2	102.0	26.9	3.0	190.0	50.2	3.0	242.0	63.9	3.5	284.0	75.0
3.5	350	117.4	-	-	-	-	-	-	3.0	160.0	42.3	3.5	205.0	54.2	3.5	235.0	62.1

F95B			700 rpm			900 rpm			1400 rpm			1750 rpm			2500 rpm		
Bar	kPa	ft	kW	l/min	USGPM	kW	l/min	USGPM	kW	l/min	USGPM	kW	l/min	USGPM	kW	l/min	USGPM
0.5	50	16.8	0.75	182.6	48.2	1.1	236.5	62.5	1.5	384.2	101.5	2.2	483.6	127.8	4.0	626.7	165.5
1.0	100	33.5	1.1	172.7	45.6	1.1	231.3	61.1	1.5	372.0	98.3	3.0	472.9	124.9	5.5	617.9	163.2
1.5	150	50.3	1.1	160.1	42.3	1.5	214.5	56.7	2.2	350.4	92.6	3.0	444.1	117.3	5.5	583.8	154.2
2.0	200	67.1	1.1	132.3	35.0	1.5	181.0	47.8	3.0	315.4	83.3	3.5	406.2	107.3	5.5	553.1	146.1
2.5	250	83.8	1.5	79.5	21.0	2.2	137.8	36.4	3.0	267.6	70.7	4.0	361.3	95.5	7.5	506.4	133.8

# ENGINE COOLING

## Raw Water Handling

Flexible impeller pumps of Johnson Pump F-series provide an efficient solution to most raw water pumping needs. The primary advantage of a flexible impeller pump is that it is self-priming. As the vanes of the impeller are depressed and rebound, they create their own vacuum drawing fluid into the pump. A dry pump can lift water up to as much as 3 metres. Thus a flexible impeller pump being used for engine cooling needs not be located below the water line or manually primed. An added feature of flexible impeller pumps is that they can pass fairly large solids without clogging or damaging the pump. This reduces the need for filtering the incoming fluid. For general raw or fresh water applications, the standard long lasting neoprene rubber impeller is used.

### Capacity Range

(based on water at 20°C/68°F)

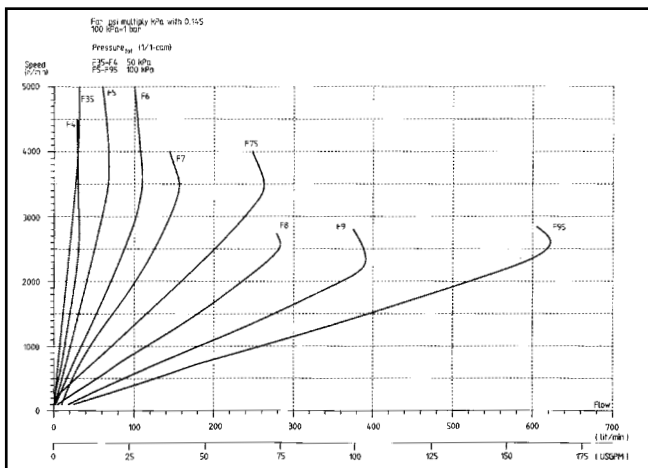

### Fresh Water Handling

For circulation of the internal, closed, fresh water circuit of the cooling system Johnson Pump can offer a number of alternatives in its DC driven CM- and C0-series (see page 19 for further information). It is also common to use a flexible impeller pump for this purpose if it is located on the cold side of the system (max. 55°C).

Other types of belt-driven centrifugal pumps may also be useful.

The closed circuit normally transfers heat from the engine to the heat exchanger. The liquid is water and anti-freeze.

### Cooling Capacity

The required output of the cooling pump – raw water as well as fresh water handling – is related to

- engine size and type (gasoline or diesel)
- type of cooling system (size of heat exchanger)
- water cooled engine oil, reverse gear, exhaust system

Contact your local dealer for more information, or for indirect cooling systems your supplier of heat exchangers.

A general feature of all flexible impeller pumps is that they cannot be permitted to run dry for more than 30 seconds. Both the impeller and the seals depend upon the water for lubrication and will soon burn out if run dry. Wearing parts are easily replaceable, and service kits are available for all standard models.

(See our Spare part list JP-1400/01)

### Different types of cooling systems

#### Direct cooling

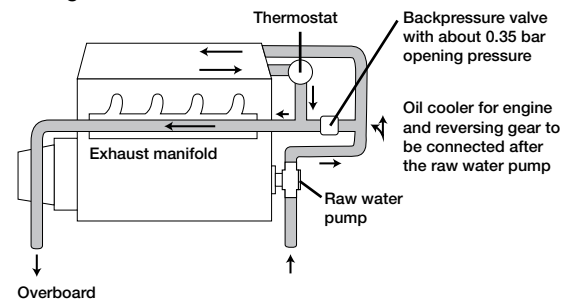

#### Indirect cooling

##### Inter cooling

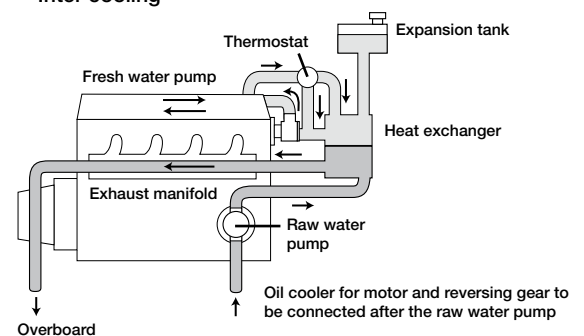

##### Keel cooling

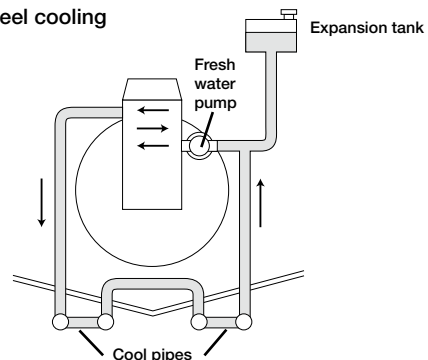

## Pump Mounting

Johnson Pump engine cooling pumps, the F-series (flexible impeller pumps) are available in several different styles and sizes to satisfy different cooling system needs. Flanged pumps which mount directly to the engine and crank shaft pulley mounted pumps are available for a wide variety of engines. Johnson Pump is the original equipment pump supplier to the largest manufacturers world-wide of inboard engines. Both flange mounted and pulley driven pedestal pumps can be used to provide cooling with a maximum of ease and flexibility. Pump ports are available in sizes from  $\frac{3}{8}$ " to  $2\frac{1}{2}$ ".

## Flange Mounted Pumps

Flanged pumps are normal pumps produced in high volumes, customer designed for flange-mounting at a power take off of the engine. Different types of drives can be used but mainly gears or any type of driving members are used.

## Crank Shaft Pulley Mounted

These pumps are designed for direct installation on the engine crank shaft pulley. Max. revs. 5.000 per minute. For some engines an adaptor kit for the engine crank shaft pulley is available.

To prevent the pump from rotating, a torque bracket from the fastening point on the pump body to a suitable point on the engine has to be used.

## Pedestal Mounted Pumps

Pulley driven pedestal mounted pumps are used when a free driving pulley is available on the engine.

Two different types of pedestal mounted pumps are supplied by Johnson Pump.

- **FB-8**

A range of bronze pumps in compact design. Ideal as cooling water pumps in marine engines. Available in sizes from  $\frac{3}{8}$ " to  $1\frac{1}{2}$ ", all with permanently lubricated double ball bearings and mechanical seal. (See page 24-25 for further information.)

- **FB-3000**

A range of extra heavy duty pedestal mounted pumps excellent for cooling purpose in commercial vessels. The design means separate bearing housings with permanently lubricated double ball bearings, mechanical shaft seal for extended service life. Wetted parts as wear plate, cam and endcover are easily replaceable. (See page 26-27 for further information.)

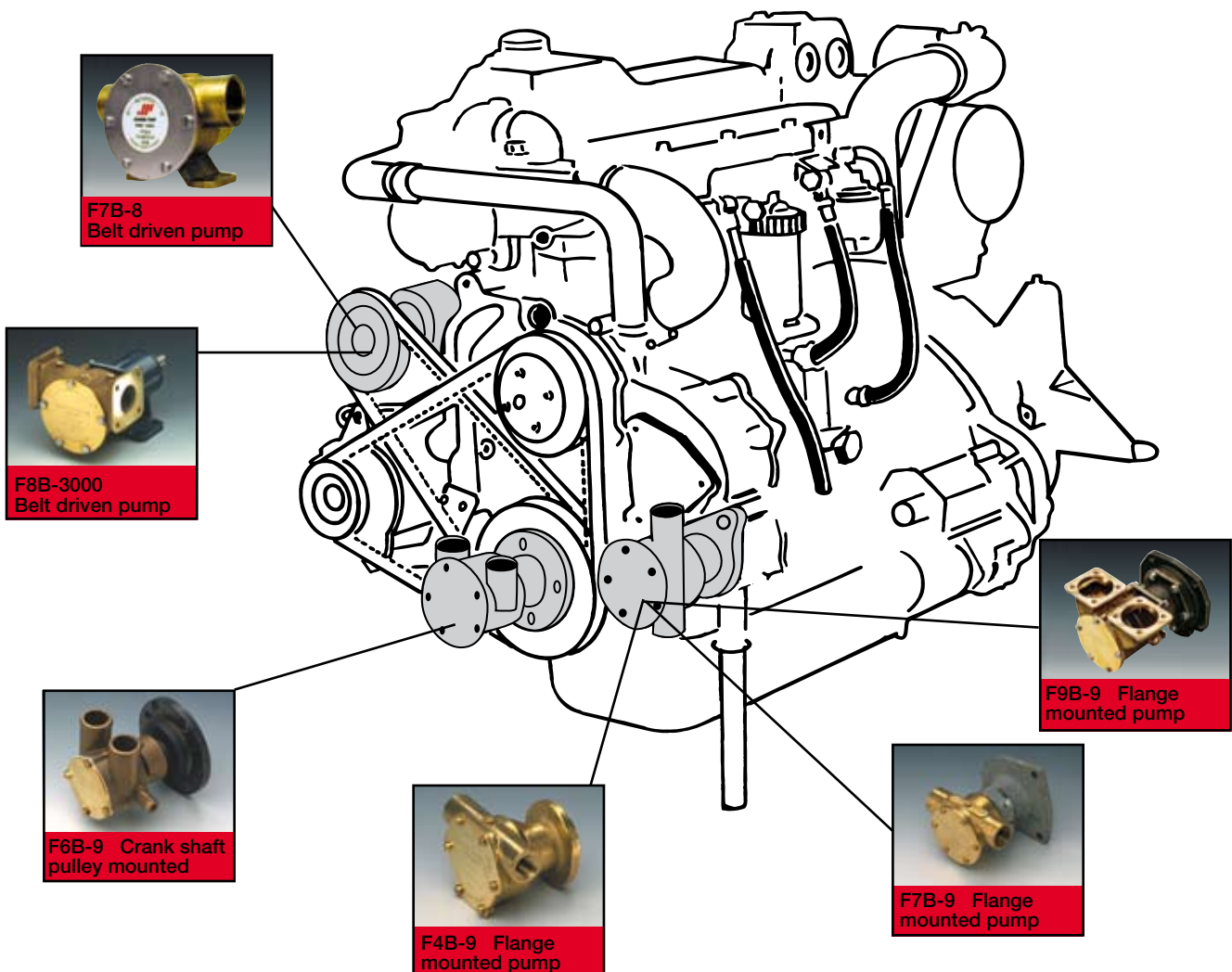

# IMPELLER IDENTIFICATION GUIDE

## Take good care of the cooling system change to a new impeller every year

The impeller is a very important security device. Its task is to pump the water through the cooling system of the engine. But remember that the impeller should be replaced every year. And always make sure you get a Johnson Pump original impeller. Then you'll know that it matches your pump exactly.

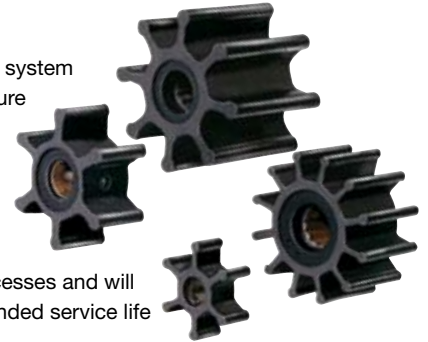

## A new impeller compound MC97

MC97 has been developed to meet new environmental regulations for rubber manufacturing processes and will replace our regular Neoprene compound. The development of MC97 has also resulted in an extended service life of the impeller compared to impellers in Neoprene.

MC97 requires new guidelines for handling impeller replacement as well as guidelines for standard- and engine cooling flexible impeller pumps for OEM-engine manufactures. Please note that these guidelines are also valid for our regular Neoprene compound. All new MC97 impellers, impeller kits and service kits containing MC97 impellers will be supplied with a JP impeller lubricant.

## Johnson Pump Impeller Bar

We can now offer a new impeller stand that can rotate and have room for 10 of our most popular spare impellers up to size F7.

Display size: Height 750mm incl. tosign Width 500 mm

Included are:

- Impellerguide with 1/1 size illustration of all our impellers
- 5 pcs 09-806B-1
- 5 pcs 09-808B-1
- 5 pcs 09-810B-1
- 5 pcs 09-1026B-1
- 5 pcs 09-801B
- 5 pcs 09-1027B-1
- 5 pcs 09-1028B
- 5 pcs 09-1052S-9
- 5 pcs 09-1077B-9
- 5 pcs 09-824P-9



Order No: 09-46854

Complete stand including above impellers

## Give your impeller a good life!

Lubricate with Johnson Pump Impeller Lubricant, optimize the priming ability at first start or after seasonal storage. Now available in Counter display box with 150 pcs Impeller lubricant packages.

Order No. 09-47086

Impeller Lubricant box



## This is how to remove the old impeller

Remove the impeller with a slip joint plier or a Johnson Pump Impuller.



Order No.

09-950-9300

JP Impuller

## This is how to fit the new one

Lubricate the shaft and the inside of the pump body and the end cover. Use Johnson Pump lubrication to help develop prime and prevent damage from dry-running the pump at initial start-up. Mount the impeller by making a pushing and twisting movement in the rotating direction. Lubricated impellers should not be stored for extended periods of time. Engine should be run after installation of a new impeller to wash out the lubrication. These recommendations apply to any service work on the pump and its components that require the use of lubrication inside the pump for assembly and start-up.

**Warning! Only use Johnson Pump Lubrication. Other products can damage the impeller, which will damage the pump and lead to engine failure. Do not run the impeller without water or lubricant, this can cause engine failure or a fire.**

The impellers are illustrated in full scale which means that you can identify your impeller without knowing the part number.

Impeller article number 09-1077B-9  
Nitrile (oil resistant)

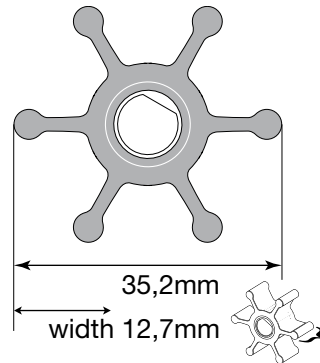

**F2**

Impeller article number 09-1052S-9  
Nitrile (oil resistant)

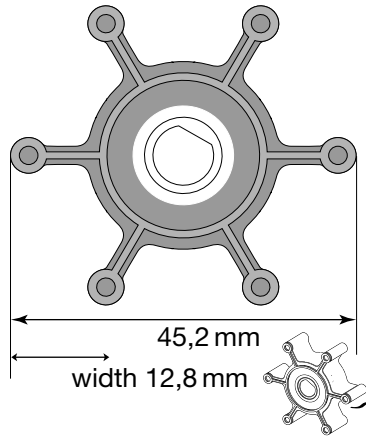

**F3**

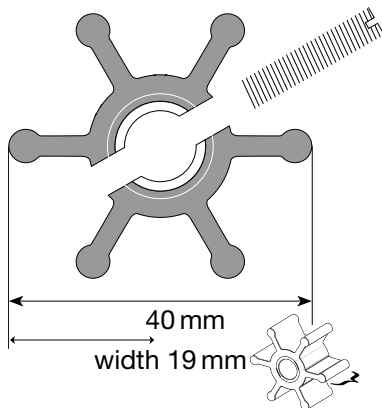

Impeller article number 09-806B-1  
MC97 (for cooling)  
replaces Jabsco 4528-0001 Europe & USA  
inner diameter 9,5 mm

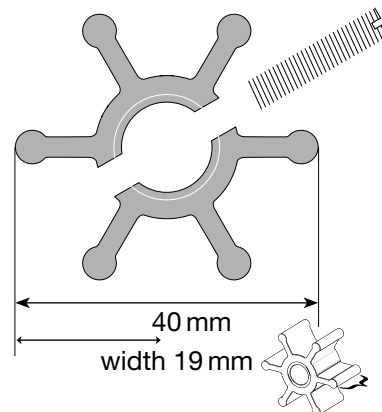

Impeller article number 09-808B-1  
MC97 (for cooling)  
replaces Jabsco 22405-0001 Europe & USA  
inner diameter 12 mm

**F35**

F4

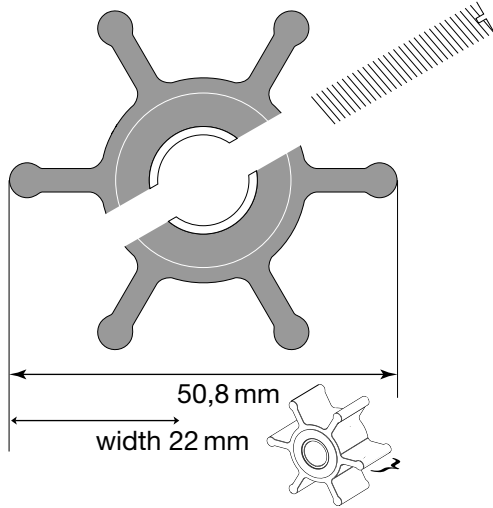

Impeller article number 09-810B-1  
MC97 (for cooling)  
*replaces Jabsco 18653-0001 Europe & USA*

Impeller article number 09-810B-9  
Nitrile (oil resistant)  
inner diameter 12 mm

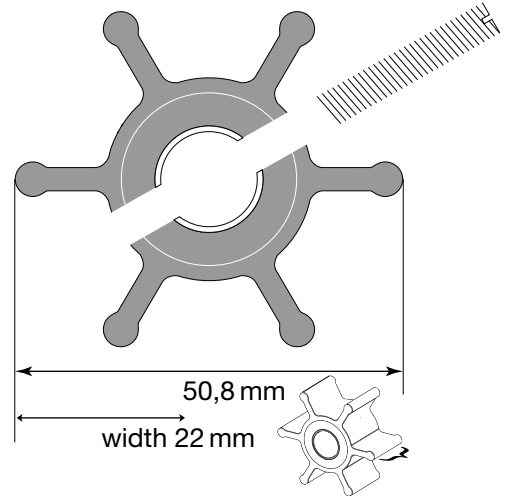

Impeller article number 09-1026B-1  
MC97 (for cooling)  
*replaces Jabsco 673-0001 Europe & USA*

Impeller article number 09-1026B-9  
Nitrile (oil resistant)  
*replaces Jabsco 673-0003 Europe & USA*  
inner diameter 12,7 mm

F4

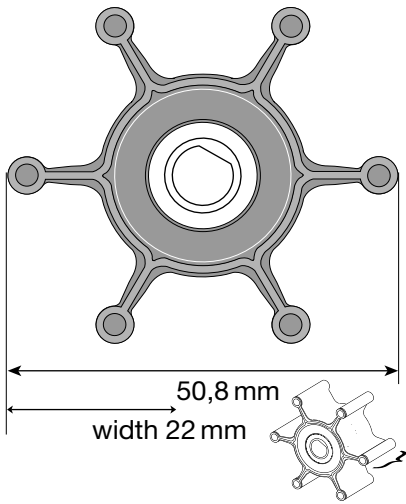

Impeller article number 09-824P-9  
Nitrile (oil resistant)  
*replaces Jabsco 6303-0003 Europe & USA*

Impeller article number 09-824P-1  
MC97 (Ultra Ballast)

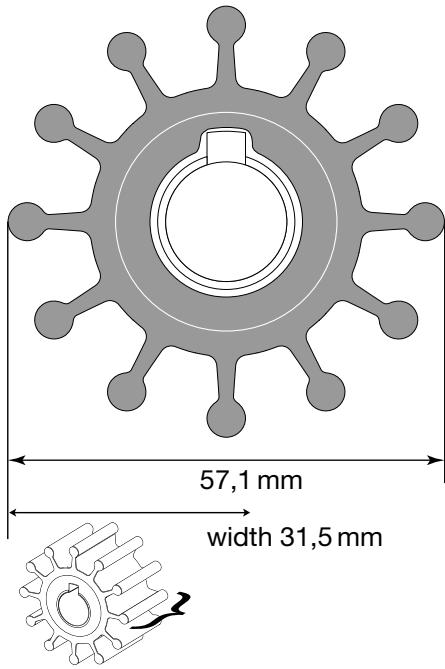

# F5

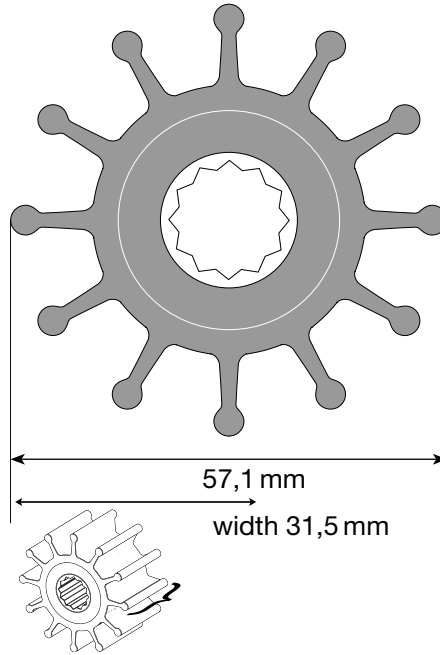

Impeller article number 09-801B  
 Neoprene (for cooling)  
 replaces Jabsco 4568-0001 Europe & USA  
 inner diameter 15,9 mm/key

Impeller article number 09-1027B-1  
 MC97 (for cooling)  
 replaces Jabsco 1210-0001 Europe & USA  
 Impeller article number 09-1027B-9  
 Nitrile (oil resistant)  
 replaces Jabsco 1210-0003 Europe & USA

# F6

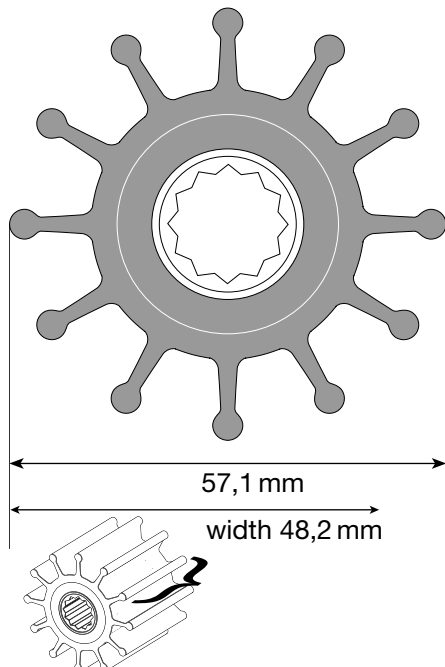

Impeller article number 09-812B-1  
 MC97 (for cooling)  
 replaces Jabsco 13554-0001 USA

# F7

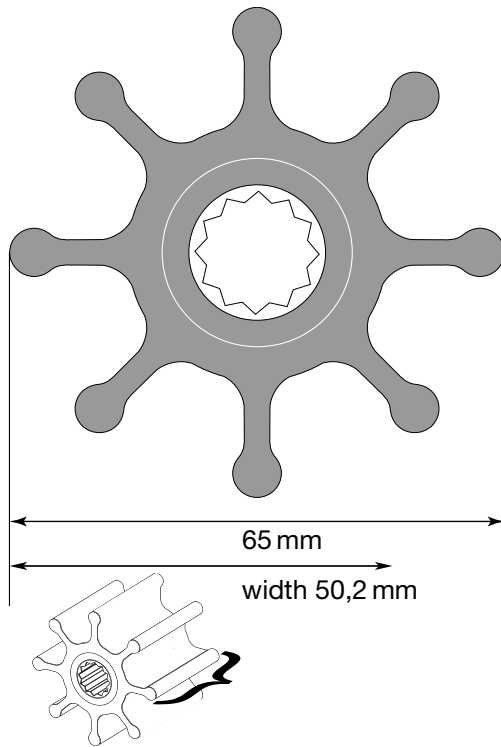

Impeller article number 09-1028B  
Neoprene (for cooling)  
*replaces Jabsco 17937-0001 Europe&USA*  
Impeller article number 09-1028B-9  
Nitrile (oil resistant)  
*replaces Jabsco 17937-0003 Europe&USA*

# F75

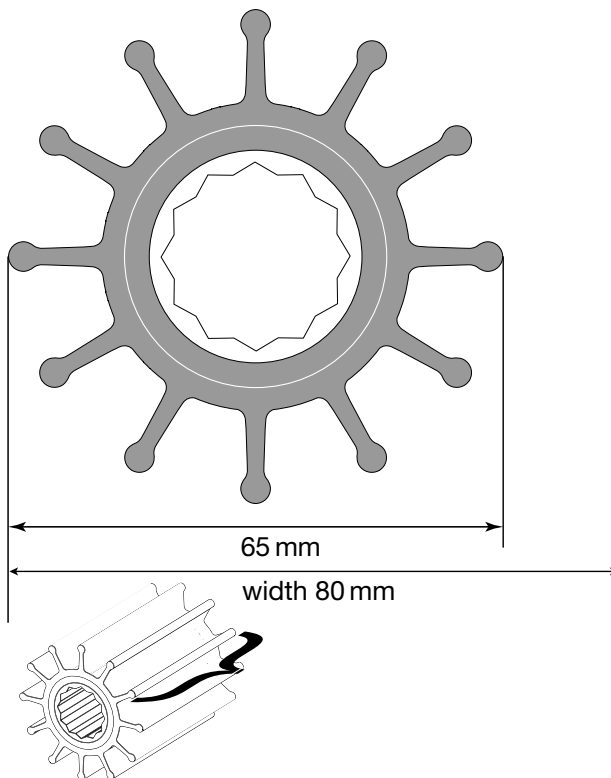

Impeller article number 09-821B  
Neoprene (for cooling)

**F8**

Impeller article number **09-819B**  
Neoprene (for cooling)  
*replaces Jabsco 836-0001 Europe &  
17935-0001 USA*

Impeller article number **09-819B-9**  
Nitrile (oil resistant)  
*replaces Jabsco 836-0003 Europe &  
17935-0003 USA*

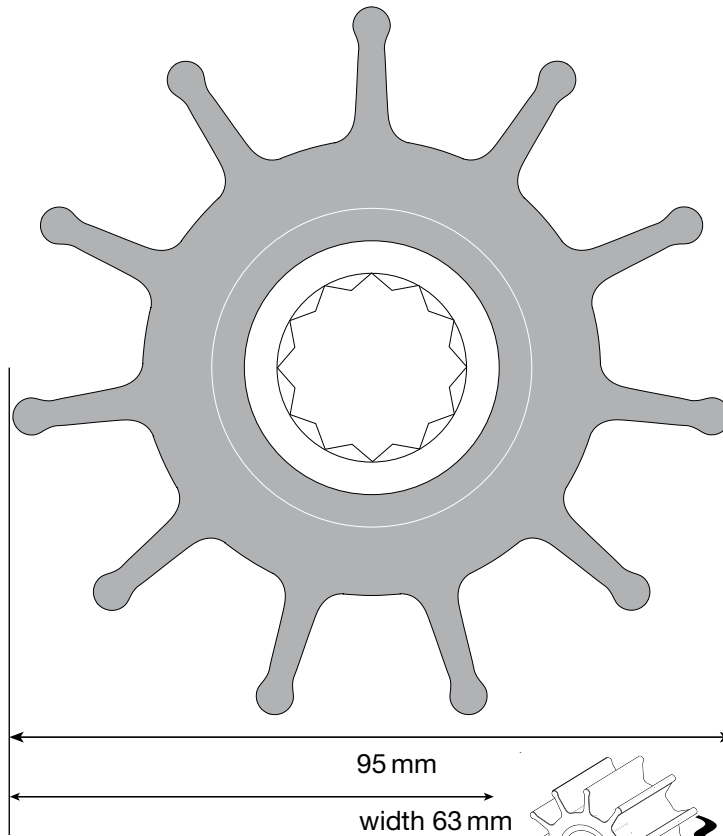

**F8**

Impeller article number **09-1029B**  
Neoprene (for cooling)  
*replaces Jabsco 836-0001 Europe &  
17935-001 USA*

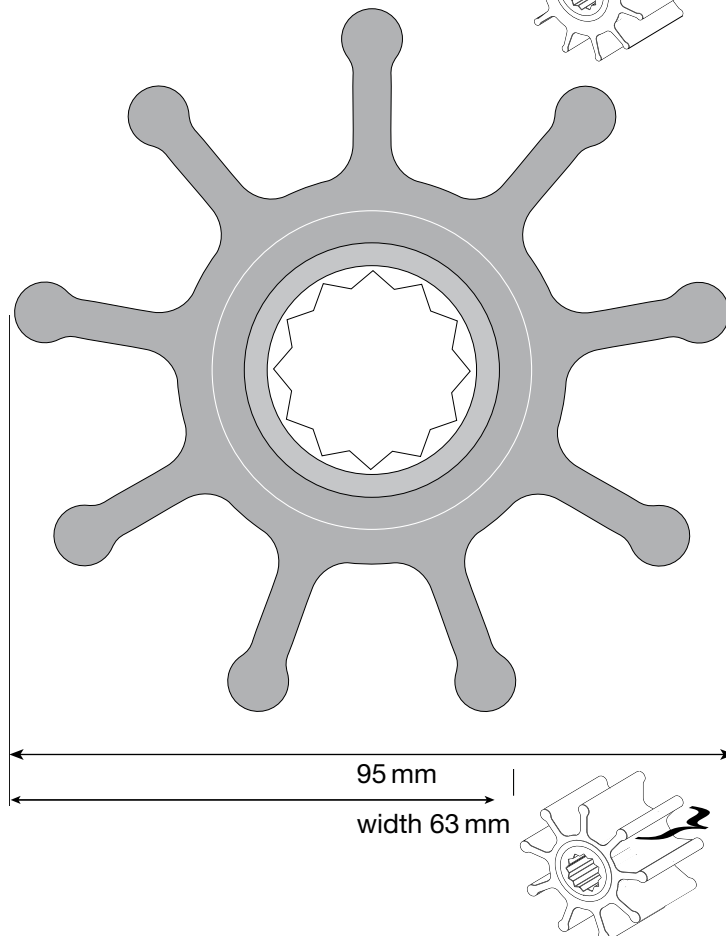

**F9**

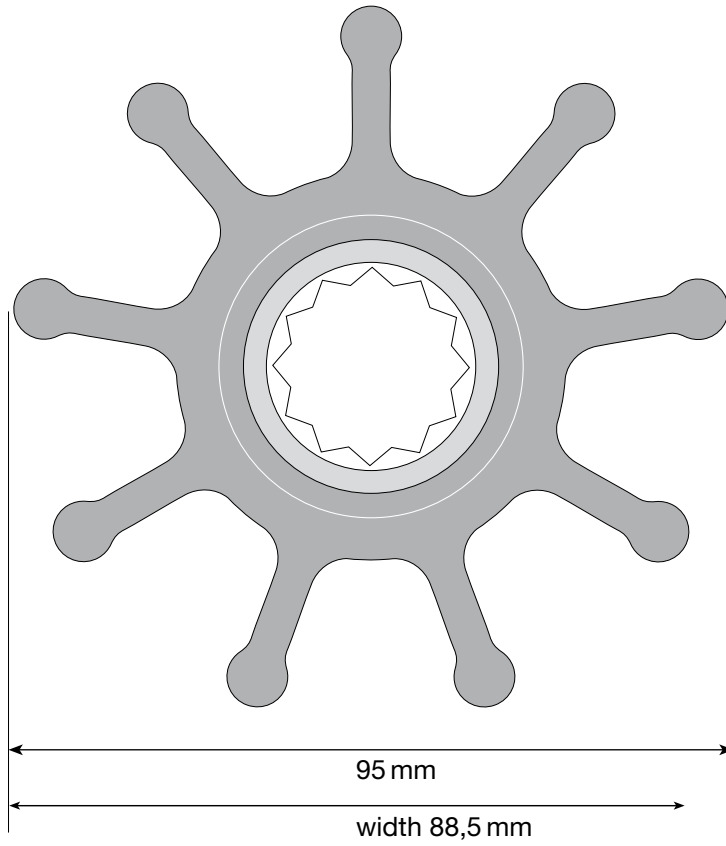

Impeller article number 09-802B  
Neoprene (for cooling)  
*replaces Jabsco 6760-0001 Europe & USA*

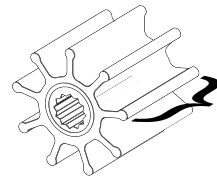

**F9**

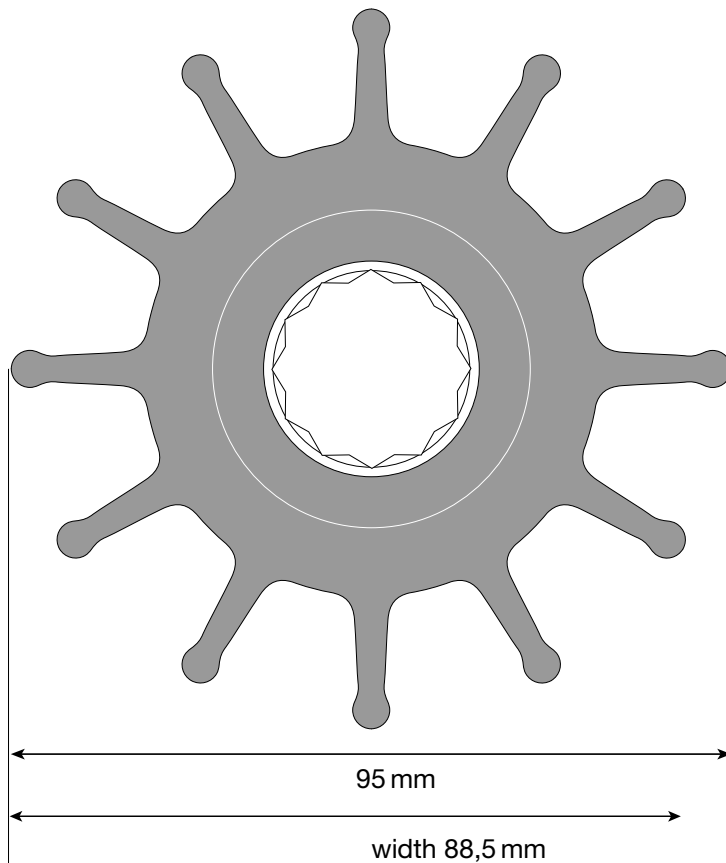

Impeller article number 09-814B  
Neoprene (for cooling)  
*replaces Jabsco 21676-0001 Europe &  
17936-0001 USA*

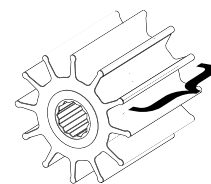

# F95

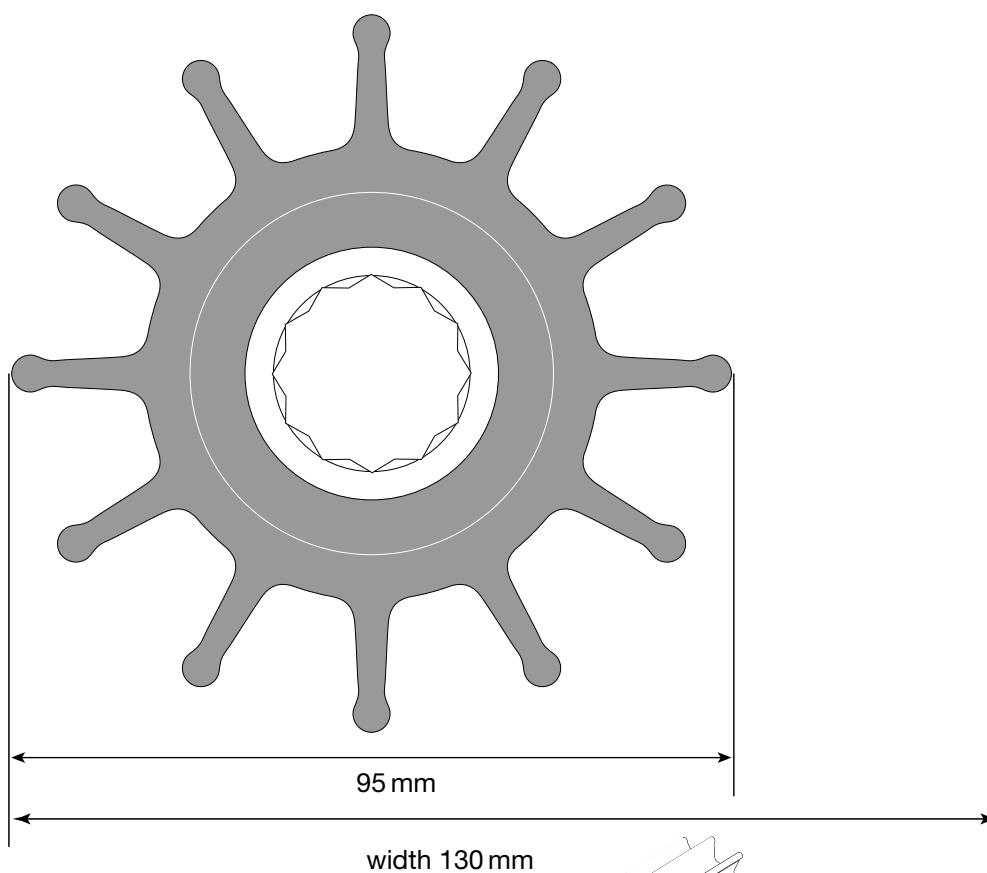

Impeller article number 09-820B  
Neoprene (for cooling)

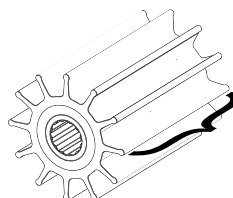





Johnson Pump Marine Nastagatan 19, P.O. Box 1436, SE-701 14 Orebro, Sweden, Phone 46 19 21 83 00, Fax 46 19 27 23 72  
Johnson Pumps of America, Inc. 10509 United Parkway, Schiller Park, Illinois 60176, USA, Phone 847-671-7867, Fax 847-671-7909  
Johnson Pump (Australia) Pty. Ltd. P.O. Box 427, Cannon Hill, QLD. 4170, Australia, Phone 617 3899 9933, Fax 61 7 3899 8574  
[www.johnson-pump.com/jpmarine](http://www.johnson-pump.com/jpmarine)